



扫一扫，
获得更多资讯

服务热线：4008-836115

INSTRUCTION HANDBOOK

PSCB Electric Stackers (PSCB 12/16/18)

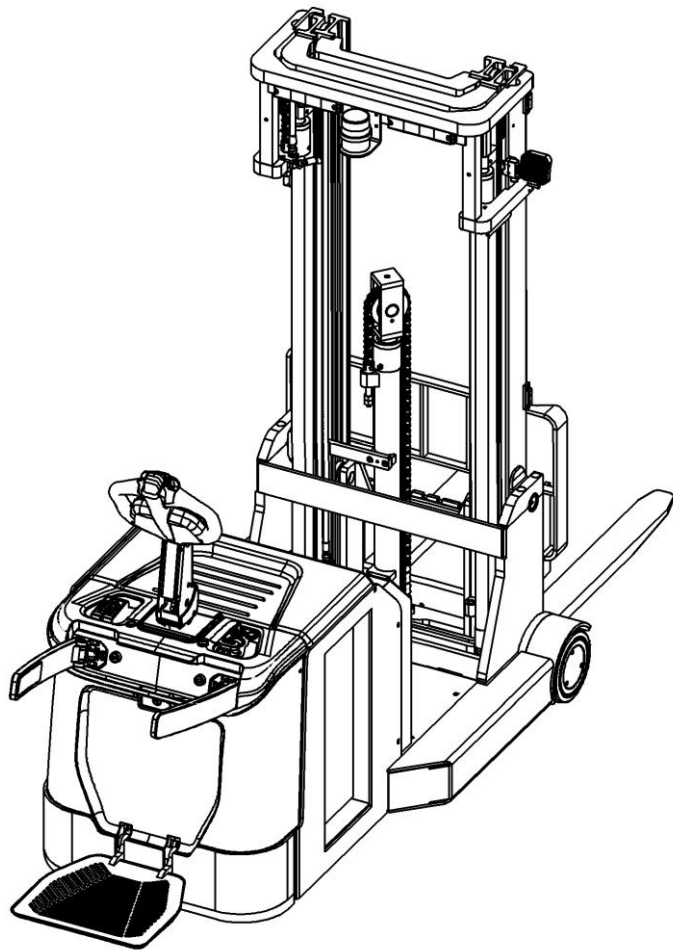

WARNING

Do not use the electric truck before reading and understanding these operating instructions.

NOTE:

- Please check the designation of your present type at the last page of this document as well as on the ID-plate.
- Keep for future reference.

Version 06/2019

PSCB 12/16/18-SMS-001-CHN

FOREWARD

Before operating the electric stacker, read this ORIGINAL INSTRUCTION HANDBOOK carefully and understand the usage of the truck completely. Improper operation of the truck may create a danger situation. This handbook describes the usage of different electric stackers. When operating and servicing the truck, make sure, that it applies to your type.

Keep this handbook for future reference. If this or the warning/caution labels are damaged or got lost, please contact your local dealer for replacement.

This truck complies with the requirements according to EN 3691-1 (Industrial trucks - safety requirements and verification, part 1), EN 12895 (Industrial trucks - electromagnetic compatibility), EN 12053 (Safety of industrial trucks- test methods for measuring noise emissions), EN 1175-1 (Industrial truck safety – electrical requirements), assumed the truck is used according to the described purpose.

The noise level for this machine is < 70 dB(A) according to EN 12053.

The vibration is 0,85 m/s² (if equipped with a platform) according to EN 13059.

ATTENTION:

- Environmentally hazardous waste, such as batteries, oil and electronics, will have a negative effect on the environment or health, if handled incorrectly.
- The waste packages should be sorted and put into solid dustbins according to the materials and be collected disposal by local special environment protection bureau. To avoid pollution, it's forbidden to throw away the wastes randomly.
- To avoid leaking during the use of the products, the user should prepare some absorbable materials (scraps of wooden or dry duster cloth) to absorb the leaking oil in time. To avoid second pollution to the environment, the used absorbable materials should be handed in to special departments in terms of local authorities.
- Our products are subject to ongoing developments. The information written in this handbook is provided as reference for operating and servicing the stacker and may vary in terms of description of particular features of the truck.



NOTE: On this manual, the left sign means warning and danger, which can lead to death or serious injury if not followed.

Copyright

The copyright remains with the company, mentioned on the CE- certificate at the end of this document.

TABLE OF CONTENTS

1. CORRECT APPLICATION	3
2. DESCRIPTION OF THE STACKER.....	4
a. Overview of the main components	4
b. Main technical data	7
c. Description of the safety devices and warning labels (Europe and other, except USA).....	9
d. Identification plate	9
3. WARNINGS, RESIDUAL RISK AND SAFETY INSTRUCTIONS	9
4. COMMISSIONING, TRANSPORTING, DECOMMISSIONING	10
a. Commissioning.....	10
Dimension [mm].....	10
b. Lifting/transportation	11
c. Decommissioning.....	11
5. DAILY INSPECTION.....	11
6. OPERATING INSTRUCTIONS	12
a. Parking	13
b. Residual lift diagram	13
c. Lifting.....	13
d. Lowering.....	13
e. Mast tilts forward and backward	13
f. Travelling.....	14
g. Steering.....	15
h. Braking	15
i. Malfunctions	16
j. Emergency	16
7. PIN-CODE PANEL	16
8. BATTERY CHARGING AND REPLACEMENT	17
a. Replacement.....	18
b. Battery Indicator.....	18
c. Charging.....	19
9. REGULAR MAINTENANCE	20
a. Maintenance checklist.....	20
b. Lubricating points.....	22
c. Check and refill hydraulic oil	22
d. Checking electrical fuses	22
e. Removing, reattaching guarding.....	23
10. TROUBLE SHOOTING	23
11. WIRING/ CIRCUIT DIAGRAM.....	25
a. Electrical circuit diagram	25
b. Hydraulic circuit.....	27

1. CORRECT APPLICATION

It is only allowed to use this electric stacker according to this instruction handbook.

The trucks described in this handbook are self-propelled pedestrian controlled electric power stackers, with electrically powered lifting function. The trucks are designed for stacking operations in dedicated racking by lifting and lowering the palletized loads up to the desired lifting heights.

A wrong usage can cause human injuries or can damage equipment.

The operator/ the operating company has to ensure the correct usage and has to ensure, that this truck is used only by staff, which is trained and authorized to use this truck.

The truck has to be used on substantially firm, smooth, prepared, level and adequate surfaces. The truck is intended to be used for indoor applications with ambient temperatures between +5°C and + 40°C and for intensive operations without crossing permanent obstacles or potholes. Operating on ramps is not allowed. During the operation the load must be placed approximately on the longitudinal centre plane of the stacker.

Lifting or transporting of people is forbidden. During traveling the load must be lowered to the height below 300 mm.

It is not allowed to use this truck on tail lifts or loading ramps.

The capacity is marked on the load diagram as well on the Identification plate. The operator has to consider the warnings and safety instructions.

Operating lighting must be minimum 50 Lux.

Modification

No modifications or alterations to this truck which may affect, for example, capacity, stability or safety requirements of the truck, shall be made without the prior written approval of the original truck manufacturer, its authorized representative, or a successor thereof. This includes changes affecting, for example braking, steering, visibility and the addition of removable attachments. When the manufacturer or its successor approve a modification or alteration, they shall also make and approve appropriate changes to capacity plate, decals, tags and operation and maintenance handbooks.

By not observing these instructions, the warranty becomes void.

2. DESCRIPTION OF THE STACKER

a. Overview of the main components

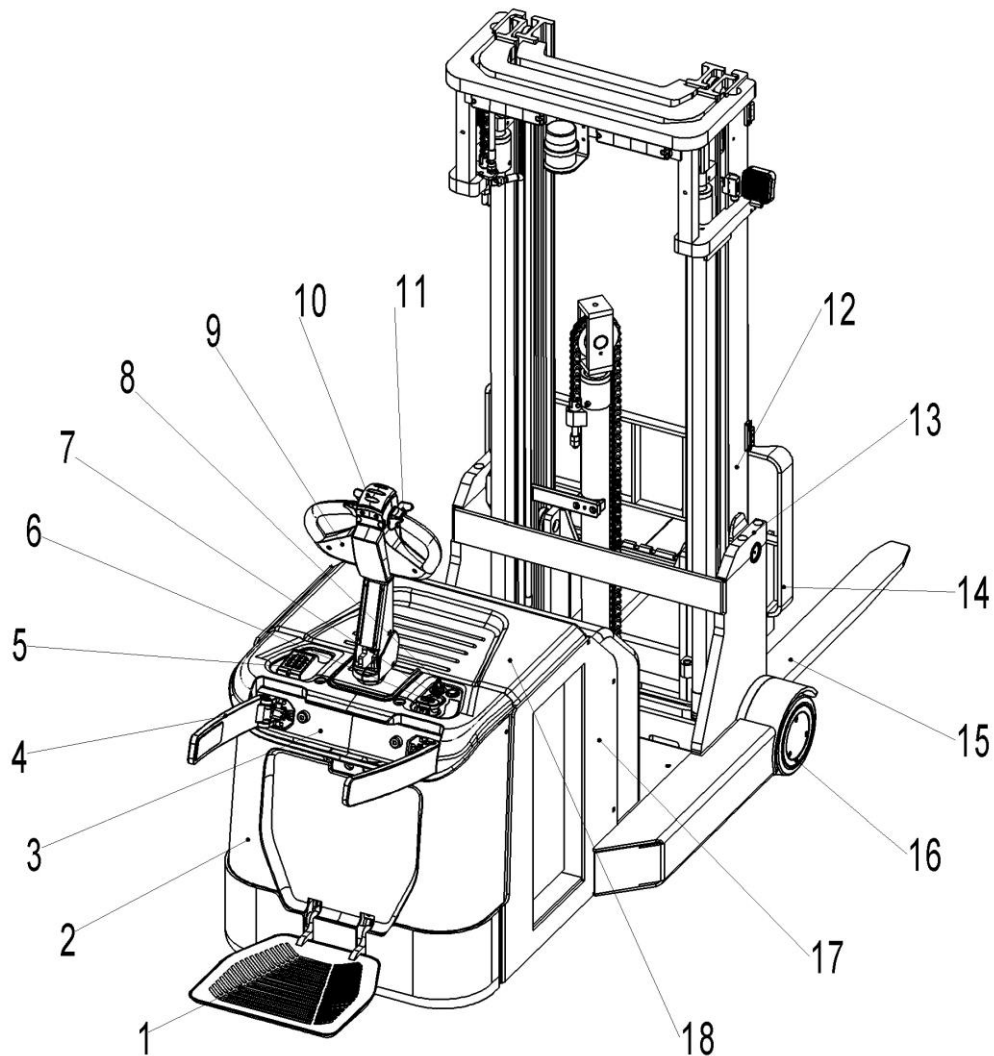

Fig. 1: Overview main components

- | | |
|----------------------------|--------------------------------|
| 1. Platform | 10. Safety button/Belly button |
| 2. Main cover | 11. Accelerator |
| 3. Protective arm cover | 12. Mast |
| 4. Protective arm | 13. Pressing plate |
| 5. Pin-code panel (option) | 14. Load backrest |
| 6. Emergency button | 15. Fork |
| 7. Discharge indicator | 16. Load roller |
| 8. Key switch | 17. Chassis |
| 9. Tiller | 18. Battery cover |

b. Main technical data

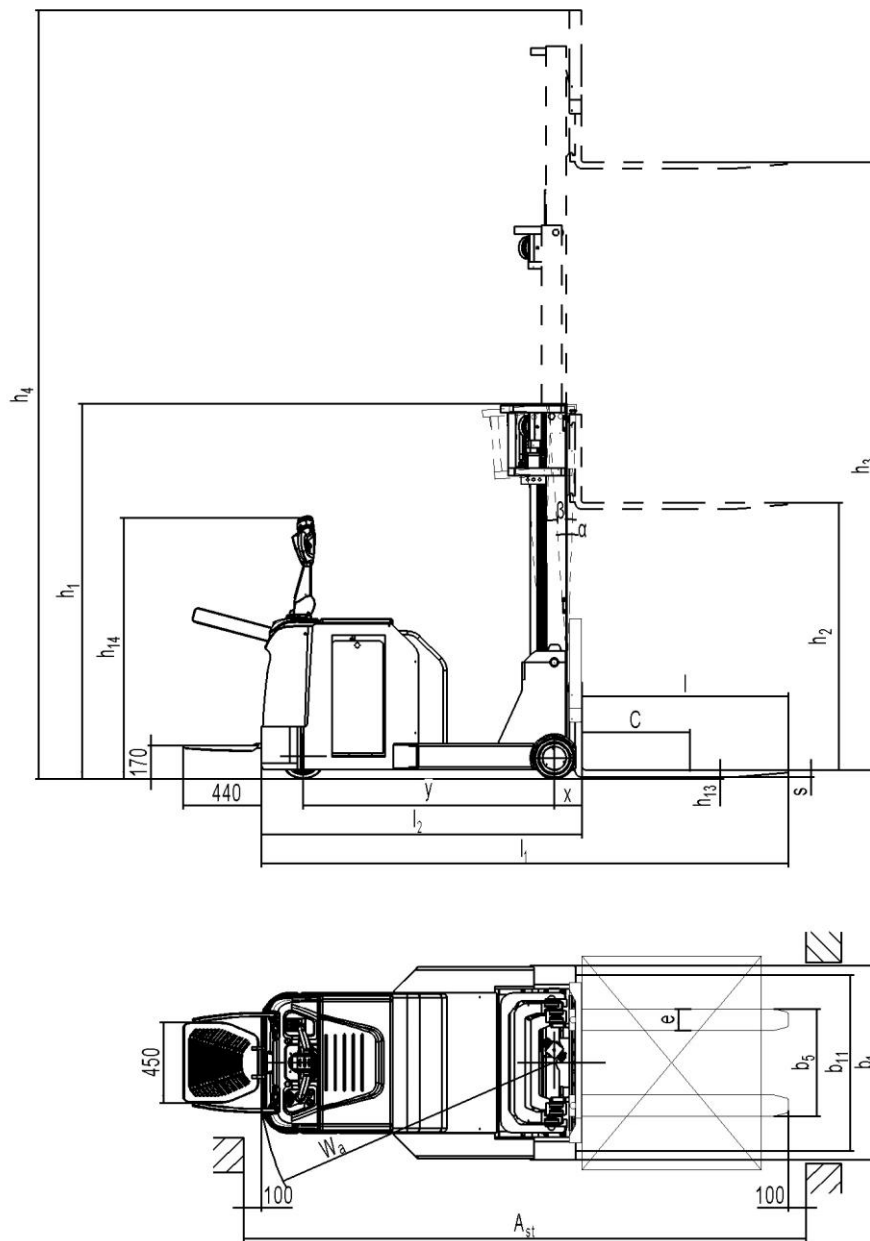

Fig. 2: Technical data

Table1: Main technical data for standard version

Type sheet for industrial truck acc. to VDI 2198						
Distinguishing mark	1.2	Manufacturer's type designation		PSCB 12	PSCB 16	PSCB 18
	1.3	Power (battery ,diesel, petrol, gas, manual)		Battery		
	1.4	Operator type		Pedestrian/		
	1.5	Load Capacity / rated load	Q(t)	1200	1600	1800
	1.6	Load centre distance	c(mm)	500		
	1.8	Load distance ,centre of drive axle to fork	x(mm)	150		
	1.9	Wheelbase	Y(mm)	1350	1450	1700

Weight	2.1	Service weight	kg	2165	2265	2450
	2.2	Axle loading, laden front/rear	kg	420/2945	381/3484	565/3725
	2.3	Axle loading, unladen front/rear	kg	985/1180	1082/1182	1238/1212
Tires, chassis	3.1	Tires		Polyurethane (PU)		
	3.2	Tire size, front	Ø x w (mm)	Ø250x82		
	3.3	Tire size, rear	Ø x w (mm)	Ø230x100		
	3.5	Wheels, number front/rear(x=driven wheels)		1x/2		
	3.6	Track, front	b10 (mm)	/		
Dimensions	4.1	Tilt of mast/fork carriage forward/backward	$\alpha / \beta (^{\circ})$	1.5/3.5		
	4.2	Lowered mast height	h1 (mm)	2100		
	4.3	Free Lift height	h2 (mm)	1500		
	4.4	Lift height	h3 (mm)	4500		
	4.5	Extended mast height	h4 (mm)	5395		
	4.9	Height of tiller in drive position min./ max.	h14 (mm)	970/1370		
	4.15	Height, lowered	h13 (mm)	60		
	4.19	Overall length	l1 (mm)	2690	2790	3060
	4.20	Length to face of forks	l2 (mm)	1740	1840	1990
	4.21	Overall width	b1 (mm)	1090		
	4.22	Fork dimensions	s/e/l (mm)	35/100/950		40/120/10
	4.25	Distance between fork-arms	b5 (mm)	220-760		
	4.32	Ground clearance, centre of wheelbase	m2 (mm)	52		
	4.33	Aisle width for pallets 1000X1200 crossways	Ast (mm)	3110	3210	3360
	4.34	Aisle width for pallets 800X1200 lengthways	Ast (mm)	3220	3320	3470
	4.35	Turning radius	Wa (mm)	1605	1705	1855
	Performance data	5.1	Travel speed, laden/ unladen	Km/h	7/8	
5.2		Lift speed, laden/ unladen	mm/s	140/200	120/200	100/200
5.3		Lowering speed, laden/ unladen	mm/s	250/200	300/200	320/200
5.8		Max. gradeability, laden/ unladen	%	6/15		
5.10		Service brake		Electromagnetic		
Electric- engine	6.1	Drive motor rating S2 60min	kW	2.6		
	6.2	Lift motor rating at S3 10%	kW	3.2		
	6.3	Battery acc. to DIN 43531/35/36 A, B, C, no		DIN		
	6.4	Battery voltage, nominal capacity K5	V/Ah	24/240	24/270	24/350
	6.5	Battery weight	kg	235	285	315
	6.6	Energy consumption acc: to VDI cycle	Kwh/h	1.75	1.88	1.90
Additional data	8.1	Type of drive control		AC- speed control		
	8.4	Sound level at driver's ear acc. to EN 12053	dB(A)	68		

C. Description of the safety devices and warning labels (Europe and other, except USA)

- A. Crane hook label
- B. Warning decal: Do not step under or on the forks
- C. Residual lift capacity sticker
- D. Never reach through
- E. Identification plate (ID-plate)
- F. Sticker to read and follow these instructions
- G. Sign of filling point
- H. Warning sticker
- J. Indicating sticker

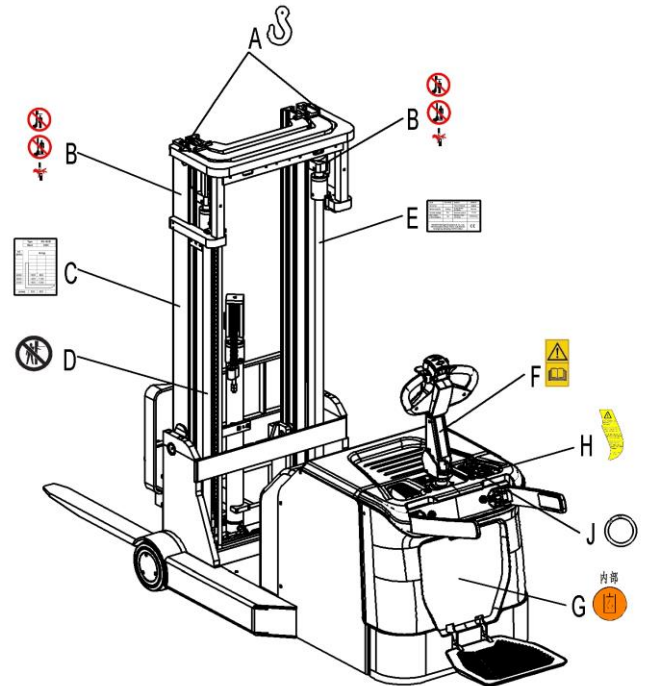

The truck has an emergency button (6) which stops all lifting-, lowering-, driving- functions and engages the failsafe electromagnetic brake when it is pushed. By pulling this button, the truck can be operated after the controller checked the functions. Before operating, insert the key and turn the switch (8) clockwise or, in case the truck is equipped with Pin-code panel, press the start-button and enter the Pin-code or use RFID access card. To prevent against unauthorized access, turn the key anti-clockwise and remove it if you do not operate this truck or, in case the truck is equipped with Pin-code panel, press the start-button or press the X button of pin-code panel. The truck is equipped with a safety (belly) button (11) which switches the driving function away from the operator, if the truck travels towards the operator and the tiller is in its operating zone. Follow also the instructions given on the decals. Replace the decals if they are damaged or missing.

d. Identification plate

- | | | | |
|---|--|----|-----------------------------------|
| 1 | Designation, type | 6 | Name and address of manufacturer) |
| 2 | Serial number | 7 | Battery weight minimum/ maximum |
| 3 | Rated capacity in kg | 8 | Nominal power in kW |
| 4 | Supply voltage in V | 9 | Load center distance |
| 5 | Own mass (self weight) in kg without battery | 10 | Manufacturing data |
| | | 11 | Option |

1	Type	xxx xx	Option	xx X xxxx	
2	Serial No.	xxxxx	Year of Manuf.	MM/YYYY	
3	Rated capacity	xxxx kg	Load center distance	xxx mm	11
4	System voltage	xx V	Nominal power	xx kW	10
5	Net weight without battery	xxx kg	Battery mass min/max	xxx / xxx kg	9
					8
6	XXXX XXXX XXXXXXXX xx XXXXX / XXXXXX			CE	7

Fig. 4: Identification plate

If sold to the EU, here the place of the CE marking

3. WARNINGS, RESIDUAL RISK AND SAFETY INSTRUCTIONS



DO NOT

- Drive outside the stacking operation with a lifted load higher than the lifting point.
- Put foot or hand under or into the lifting mechanism.
- Allow other person than the operator to stand in front of or behind the truck when it is moving or lifting/lowering.
- Overload the truck.
- Put foot in front of the wheels, injury could result.
- Lift people. People could fall down and suffer severe injury.
- Push or pull loads.
- Use this truck on ramps.
- Use the truck without a removed protective screen
- Locate load at side or end of forks. Load must be distributed evenly on the forks.
- Use the truck with unstable or unbalanced load.
- Use the truck without manufacturer's written consent.
- Lifted loads could become unstable at wind forces. In the case of wind forces do not lift the load if there is any influence to the stability

Watch difference in floor levels when driving. Load could fall down or the truck could get uncontrollable. Keep watching the condition of load. Stop operating the truck if load becomes unstable. Brake the truck and activate the emergency button (6) by pushing when sliding load on or off the truck. If the truck has any malfunctions, follow chapter 6.

Practice maintenance work according to regular inspection. This truck is not designed to be water resistant. Use the truck under dry condition. Prolonged continuous operation might cause damage of the power pack. Stop operation if temperature of hydraulic oil is too high.



- When operating the truck, the operator has to wear safety shoes.
- The truck is intended to be used for indoor applications with ambient temperatures between +5°C and + 40°C.
- The operating lighting must be minimum 50 Lux.
- It is not allowed to use the truck on ramps.
- To prevent unintended sudden movements when not operating the truck (i.e. from another person, etc.), switch off the truck and remove the key.
- Lifted loads can overlap the field of view, take all necessary safety measures and use visual aid if necessary.
- Avoid any crashes of the foldable platform against surrounding objects, especially moving in Fw direction as it may lead to crushing and shearing hazards. Always maintain safe speed according to the working environment.

4. COMMISSIONING, TRANSPORTING, DECOMMISSIONING

a. Commissioning

Table 2: Commissioning data

Type	PSCB 12	PSCB 16	PSCB 18
Commissioning weight [kg]	2250	2350	2535
Version/ Lift [mm]	4500	4500	4500
Dimension [mm]	2200x1090x2100	2300x1090x2100	2550x1090x2100

After receiving our new truck or for re-commissioning you have to do following before (firstly) operating the truck:

- Check if are all parts included and not damaged
- Install and charge the battery (follow chapter 8)
- Do the work according to the daily inspections as well as functional checks.

b. Lifting/transportation

For transporting, remove the load, lower the forks to the lowest position and fix the truck safe with dedicated lifting gear according to Fig. 5.

Lifting



**USE DEDICATED CRANE AND LIFTING EQUIPMENT
DO NOT STAND UNDER THE SWAYING LOAD
DO NOT WALK INTO THE HAZARDOUS AREA
DURING LIFTING**

Lower the forks and park the truck securely.

Fasten the truck according to fig. 6 by fixing dedicated lashing belts to each side of the truck's crane hook holes and fasten the other side at the transporting truck.

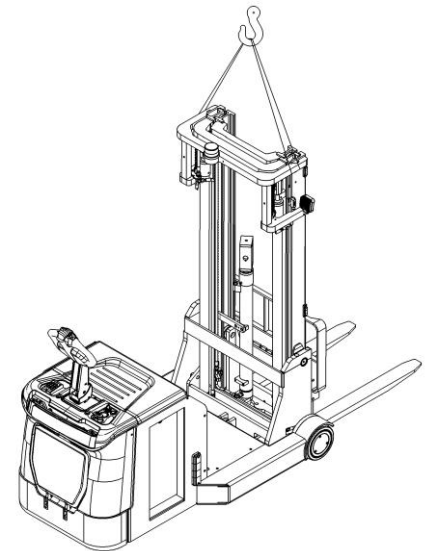

Fig.5: Lifting with a crane

Transportation



**URING TRANSPORTATION ON A LORRY OR
TRUCK, ALWAYS FASTEN THE TRUCK
SECURELY**

Lower the forks and park the truck on the metal plate securely. Fix the forks by the metal plank with two screws to the bottom metal plate. Fasten the truck by dedicated lashing belts according to fig. 6 and fasten the other side at the transporting truck.

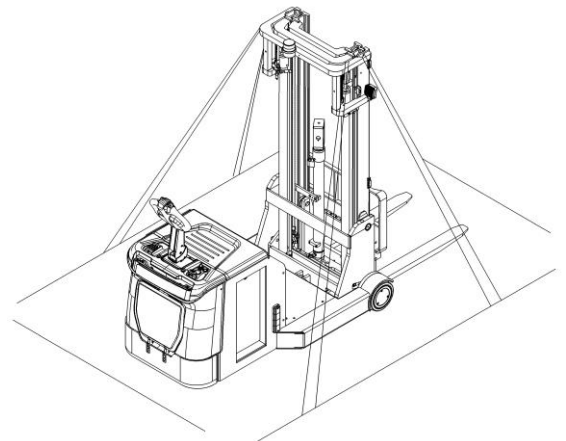

Fig. 6: Fixing points

c. Decommissioning

For storage, remove the load, lower the truck to the lowest position, grease all in this handbook mentioned greasing points (regular inspection) protecting the truck against corrosion and dust. Remove the batteries and jack the truck safely, so that there will be no flattening of wheels after storage.

For final decommissioning hand the truck to a designated recycling company. Oil, batteries and electric components must be recycled due to legal regulations.

5. DAILY INSPECTION

This chapter describes pre-shift checks before putting the truck into operation.

Daily inspection is effective to find the malfunction or fault on this truck. Check the truck on the following points before operation.



Remove load from truck and lower the forks.
DO NOT USE THE TRUCK IF ANY MALFUNCTION IS FOUND.

- Check for scratches, deformation or cracks.
- Check if there is any oil leakage from the cylinder.
- Check the vertical creep of the truck.
- Check the chain and rollers for damages or corrosion.
- Check the smooth movement of the wheels.
- Check the function of the emergency brake by activating the emergency button.
- Check, the tiller arm switch braking function.
- Check the lifting and lowering functions by operating the buttons.
- Check if the protective screen has no damages and that is correctly assembled.
- Check the audio warning signal.
- Check if all bolts and nuts are tightened firmly.
- Check the function of the key switch.
- Check the speed limitation switch.
- Visual check if there are any broken hoses or broken electric wires.
- If supplied with a backrest extension, check it for damages and correct assembling.

6. OPERATING INSTRUCTIONS

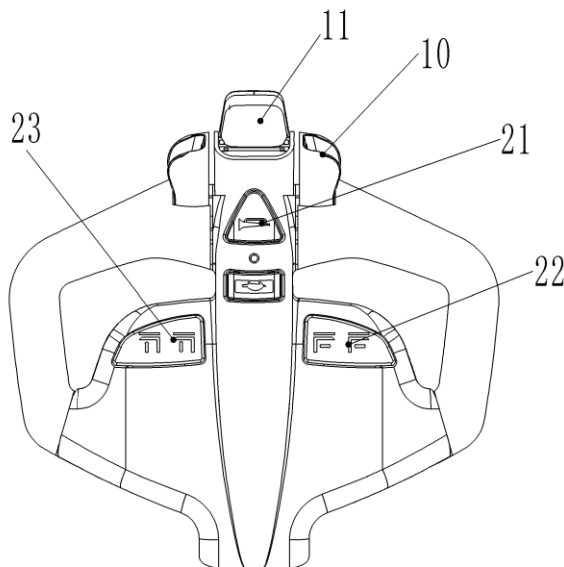

Fig.7: Tiller operating controls



BEFORE OPERATING THIS TRUCK, PLEASE FOLLOW THE WARNINGS AND SAFETY INSTRUCTIONS (CHAPTER 3). BEFORE OPERATING THIS TRUCK, ENSURE THAT THE LOAD OR OTHER EQUIPMENT NOT CAUSES INSUFFICIENT VISIBILITY!

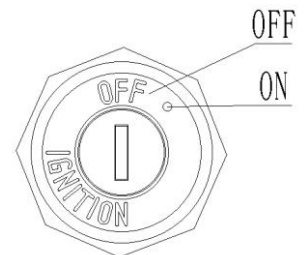

Fig. 8: Key switch

Make sure that the load is palletized and stable and that the daily inspection is carried out. For starting, insert the key and turn it clockwise to the “ON”- position. Eventually before inserting the key switch (fig.1, 8), the emergency button (fig.1, 6) must be pulled carefully.

Press the horn button (fig.7, 21) to activate the audible warning signal.

a. Parking



DO NOT PARK THE TRUCK ON INCLINED SURFACES

The truck is equipped with an electromagnetic failsafe stopping and parking brake.

Always lower the forks fully and drive the truck to a safe area. Turn the key anti- clockwise to the “Off” – position and remove the key.

b. Residual lift diagram

The residual lift diagram indicates the maximum capacity Q [kg] for a given load centre c [mm] and the corresponding lift height H [mm] for the truck with horizontal load.

The white markings on the mast indicate if the specific lifting limits reached.

For instance with a load centre of gravity distance c of 500 mm and a maximum lift height H of 4500 mm, the max. capacity Q is 900 kg.

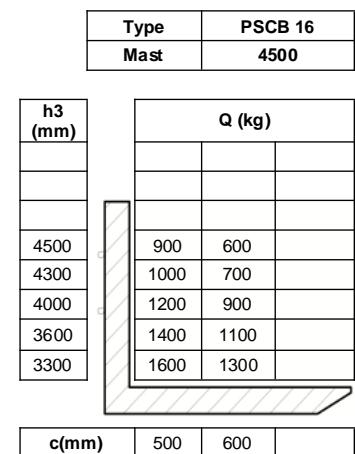

Fig. 9: Residual lift diagram

c. Lifting



DO NOT OVERLOAD THE TRUCK! THE MAXIMUM CAPACITY IS 1200/1600/1800 kg. LIFT ONLY CAPACITIES ACCORDING TO THE RESIDUAL LIFT DIAGRAM.

Travel with the lowered forks fully underneath the pallet and press the lifting button (Fig. 7, 23) until you reached the desired lifting height.

d. Lowering

If the forks are in the racking, firstly travel out of the racking carefully with or without the pallet. By travelling out of the racking, take care that the forks are not touching the racking.

Press the lowering button (Fig. 7, 23) carefully.

Lower the load until the forks are clear of the pallet, then drive the truck carefully out of the load unit.

e. Mast tilts forward and backward

Press down the forward button(fig.7, 22), mast tilts forward.

Press down the backward button(fig.7, 22), mast tilts backward.

Tilting limit switch is not triggered, the fork can be lifted to more than 1.8m.

Tilting limit switch triggered state, cargo fork lift to 1.8m limit.

Tilting forward is prohibited when the tilting limit switch is triggered above 1.8m of cargo fork.

f. Travelling



TRAVEL ON INCLINES ONLY WITH THE LOAD FACING UPHILL.

DO NOT TRAVEL ON INCLINES MORE THAN SPECIFIED WITH THE TECHNICAL DATA. TRAVELLING IS ONLY ALLOWED IF THE FORKS ARE LOWERED DOWN TO THE LIFTING POINT (<300MM).

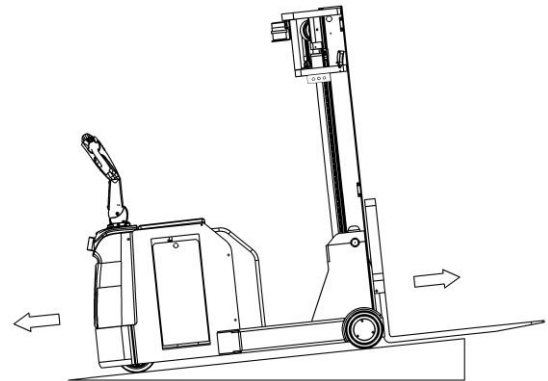

Fig.10: Load facing uphill

After starting the truck by turning the inserted key to the "ON"- position or by activation from Pin-code panel carefully move the tiller to the operating zone ('F', fig.11).

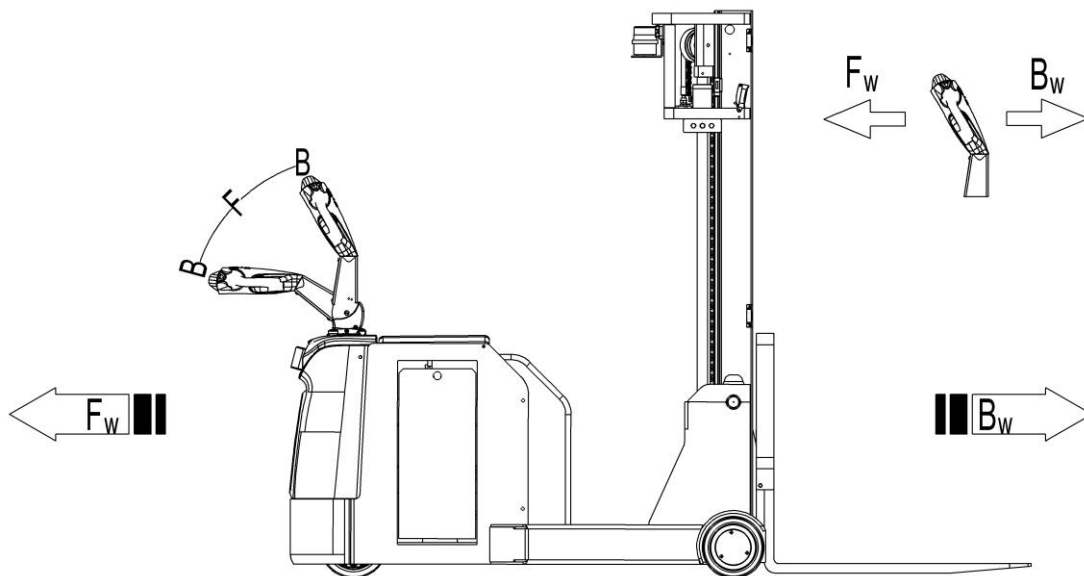

Fig.11: Operating direction

Turn the accelerator button to the desired direction forward 'Fw.' Or backwards 'Bw.'(fig. 11).

Control the travelling speed by moving the accelerator button (fig.7, 22) carefully until you reached the desired speed.

If you move the accelerator button back to the neutral position, the controller decelerates the truck until the truck stops. If the truck stopped, the parking brake will be engaged.

Drive carefully the truck to the destination. Watch the route conditions and adjust the travelling speed with the accelerator- button.



THE TRUCK IS EQUIPPED WITH A FOLDABLE PLATFORM AND SIDEWAYS PROTECTIVE ARMS. PAY ATTENTION, THE BEHAVIOR FOR THE RIDE-ON MODE IS DIFFERENT TO THE PEDESTRIAN MODE.

Besides the pedestrian mode, following travelling modes can be used:

- Travelling with platform (1) folded downside and sideways arms (4) in protective position
Travelling with maximum speed.
- Travelling with platform (1) folded downside and sideways arms (4) folded downside
Depending on the Controllers parameter setting, reduce the speed, not higher than 6km/h.
- Travelling with platform (1) folded upright and sideways arms (4) folded downside
Depending on the Controllers parameter setting, reduce the speed, not higher than 6km/h.

g. Steering



THE TRUCK IS EQUIPPED WITH ELECTRIC STEERING SYSTEM, TAKE CARE BY OPERATING A TRUCK WITH THIS KIND OF SYSTEM

Operator is steer the truck by moving the tiller to the left or right side.

h. Braking



THE BRAKING PERFORMANCE DEPENDS ON THE TRACK CONDITONS AND THE LOAD CONDITONS OF THE TRUCK

The braking function can be activated on several ways:

- By moving the accelerator button (fig.7, 10) back to the initial '0' position or by releasing the button, the regenerative braking is activated. The truck brakes until it stops.
- By moving the accelerator button (fig.7, 10) from one driving direction directly to the opposite direction, the truck brakes regenerative until it starts travelling into the opposite direction.
- The truck brakes, if the tiller is moved up or down to the braking zones ('B'). If the tiller is released, the tiller moves automatically up to the upper baking zone ('B').
The truck brakes until it stops.
- The safety (belly) button (fig.7, 11) prevents the operator from being crushed. If this button is activated, the truck decelerates and/ or starts travelling into the backwards direction ('Bw.') for a short distance and stops. Please consider, that this button also operates, if the truck is not travelling and the tiller is in the operating zone.

i. Malfunctions

If there are any malfunctions or the truck is inoperative, please stop using the truck and activate the emergency button (fig.1, 6) by pushing it. If possible, park the truck on a safe area, turn the key switch (fig.1, 8) anti- clockwise and remove the key, in case the truck is equipped with Pin-code panel, press the start-button or press the X button of pin-code panel. Inform immediately the manager and, or call your service. If necessary, tow the truck out of the operating area by using dedicated towing/ lifting equipment.

j. Emergency

In emergencies or in the event of tip over (or off dock), keep safe distance immediately. If possible push the emergency button (fig.1, 6). All electrical functions will be stopped.

7. PIN-CODE PANEL

The truck can be equipped with an optional pin-code panel (5), and a button (8) will replace the key switch (25) if equipped with pin-code panel.

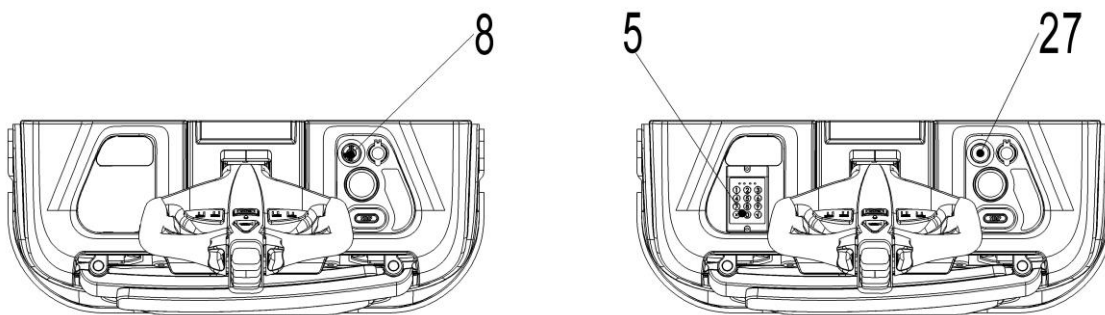

Fig.11: Pin-code panel

a. Introduction

Pin-code panel is an electronic system for access limitation. The truck will not able to be operated before typing a correct password, the main function is to prevent unauthorized operation.

b. Main parameters

Working voltage: 12V-60V

Ambient temperature: -40°C to +90°C

IP grade: IP65

c. Main functions

This pin-code panel supports Max. one password and five cards.



Please check the administrator password on the separated instruction. Default user password is 1234, you can use it immediately. If you need to change the password, please refer to separated instruction.

d. Operation

1. ID card

Put the ID card close to the code panel, there will be a short buzzer if it is a valid ID card, then the blue light is on, truck can be operated. (If the red light is on, means you made some mistakes during card start or card is not valid. The truck can't be used)

2. Password

- Type the password, press "√" button. If the password is correct the truck can be operated.
- To turn off the truck press "×". The truck will go out from the operation mode.
- To start operation again need to re-enter the password.

e. Pin-code panel indicator

Red	fault code
Yellow	waiting for further instruction
Blue	active
Green	power on

8. BATTERY CHARGING AND REPLACEMENT



- Only qualified personnel is allowed to service or charge the batteries. The instructions of this handbook and from the battery manufacturer must be observed.
- The batteries are lead-acid traction batteries with liquid electrolyte.
- Be aware about the risk of accumulation of hydrogen under battery cover, keep it opened during charging.
- Recycling of batteries undergoes with national regulations. Please follow these regulations.
- By handling batteries, open fire is prohibited, gases may cause explosion!
- In the area of battery charging neither burning materials nor burning liquids are allowed. Smoking is prohibited and the area must be ventilated.
- Park the truck securely before starting charging or installing/changing the batteries
- Before finishing the maintenance work, make sure, that all cables are connected correctly and not disturbed towards other components of the truck.

The trucks are equipped with the following lead-acid traction batteries with liquid electrolyte::

PSCB 12: 1pc 3PZS 24V/270 Ah [624x284x627 (LxWxH)]
PSCB 16: 1pc 3 PZS 24V/270 Ah [624x284x627 (LxWxH)]
PSCB 18: 1pc 3PZS 24V/350 Ah [624x284x627 (LxWxH)]



IT IS ONLY ALLOWED TO USE LEAD-ACID TRACTION BATTERIES WITH LIQUID ELECTROLYTE. THE WEIGHT OF THE BATTERIES HAS AN INFLUENCE TO THE TRUCKS OPERATING BEHAVIOR. PLEASE CONSIDER THE MAXIMUM OPERATING TEMPERATURE OF THE BATTERIES.

a. Replacement

Park the truck securely and switch off the stacker with the key (or start-button) and activate the emergency button (fig.1, 6). Disconnect battery plug and lock pin, turn up the battery locker, then pull out the battery from side.

The installation is in the reverse order.

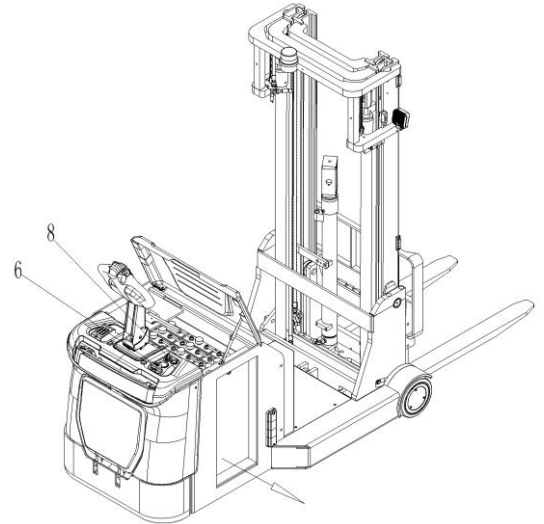
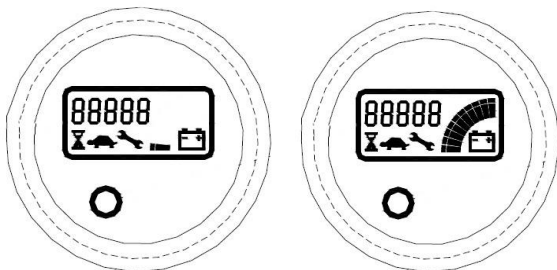

Fig. 12: Battery replacement

b. Battery Indicator



Battery discharged

Battery charged

Fig. 13: Battery discharge indicator

Hour meter

An alpha-numeric liquid crystal display is fitted in the centre of the unit that shows the hours worked. The display is backlight (the backlight is normally lighted).

Alarms

The same display can also indicate the alarm state, showing a code corresponding to the type of alarm. To attract attention, the red LED will start blinking when an alarm is generated.

Software version

When the key switch is initially closed, in case truck is equipped with pin-code panel, please press start-button and enter the Pin-code or use RFID access card, then display shows the eeprom version for a few seconds (EPXXX, where XXX represents the version) and traction controller eeprom version appears, each one for 2 seconds. Simultaneously the symbol of a monkey wrench appears.

Battery State of charge



The battery's state of charge indication is integrated in the LCD display; it is shown by ten notches. Each notch represent the 10% of the battery charge. As the battery becomes discharged, the notches turn off progressively, one after the other, in proportion to the value of the residual battery charge. This value, sent to the MDI-CAN by the controller via CAN-BUS, is displayed in the tester menu of the Zapi console connected to the controller. When BATTERY LOW alarm appears on the controller, the battery symbol which is under the notches blinks.

Turtle Symbol:



It is normally off, when it appears (fixed) it shows activation of the “soft” mode of the truck, in which maximum speed and acceleration are reduced.

Monkey Wrench Symbol:



It is normally off, when it appears (fixed) it shows the request of programmed maintenance or the alarm state. In this case the relative code will be displayed. The information supplied by the MDI-CAN can be extremely useful. Failures can be quickly identified by the operator or service technician thereby finding the fastest solution to the problem.

Hourglass Symbol:



It is normally off, it blinks when the hour meter is working.

c. Charging



- Before charging ensure that you are using an appropriate charger for charging the installed battery.
- Before using the charger, please fully understand the instructions of the charger instructions.
- Always follow these instructions.
- The room, where you are charging, must be ventilated.
- The exactly charge status can be only checked from the discharge indicator. To control the status, the charging must be interrupted and the truck must be started.

Park the truck at a dedicated secured area with a dedicated power supply.

Lower the forks and remove the load.

Open the battery cover and let it stay upright.
 Switch the truck off and connect the battery plug to the charging plug of the charger.
 The charger starts charging the battery if the charger is connected to the main power supply.
 Disconnect the battery plugs after the charger finished charging.
 Connect the battery plug with the plug at the truck.
 Close the battery cover.

9. REGULAR MAINTENANCE



- Only qualified and trained person is allowed to do maintenance on this truck.
- Before maintaining, remove the load and lower the forks to the lowest position.
- If you need to lift the truck, follow chapter 4 b by using designated lashing or jacking equipment. Before working, put safety devices (for instance designated lift jacks, wedges or wooden blocks) under the truck to protect against accidental lowering, movement or slipping.
- Please pay attention by maintain the tiller arm, platform or protective arms. The gas pressure springs are pre-loaded by compression. Carelessness can cause injury.
- Use approved and from your dealer released original spare parts.
- Please consider that oil leakage of hydraulic fluid can cause failures and accidents.
- It is allowed to adjust the pressure valve only from trained service technicians.

If you need to change the wheels call your service partner as the procedure requires use of special lifting equipment and needs to be performed by trained personnel. The castors must be round and they should have no abnormal abrasion.
 Check the items emphasized maintenance checklist.

a. Maintenance checklist

Table 3: Maintenance checklist		Interval (Month)			
		1	3	6	12
	Hydraulic				
1	Check the hydraulic cylinder, piston for damage noise and leakage		•		
2	Check the hydraulic joints and hose for damage and leakage		•		
3	Inspect the hydraulic oil level, refill if necessary		•		
4	Refill the hydraulic oil (12 months or 1500 working hours)				•
	Mechanical system				
5	Inspect the forks for deformation and cracks		•		
6	Check the chassis for deformation and cracks		•		
7	Check if all screws are fixed		•		
8	Check mast and chain for corrosion, deformation or damages, replace if necessary	•			
9	Check the gearbox for noise and leakage		•		
10	Check the wheels for deformation and damages, replace if necessary		•		
11	Lubricate the steering bearing				•
12	Inspect and lubricate the pivot points		•		

13	Lubricate the grease nipples	•			
14	Replace the guarding and/or protective screen if it is damaged	•			
Electric system					
15	Inspect the electric wiring for damage		•		
16	Check the electric connections and terminals		•		
17	Test the Emergency switch function		•		
18	Check the electric drive motor for noise and damages		•		
19	Test the display		•		
20	Check if correct fuses are used, if necessary replace.		•		
21	Test the audio warning signal		•		
22	Check the contactors		•		
23	Check the frame leakage (insulation test)		•		
24	Check function and wear of the accelerator		•		
25	Check the electrical system of the drive motor		•		
Braking system					
26	Check brake performance, if necessary replace the brake disc or adjust the air gap		•		
Battery					
27	Check the battery voltage		•		
28	Clean and grease the terminals and check for corrosion and damage		•		
29	Check the battery housing for damages		•		
Charger					
30	Check the main power cable for damages			•	
31	Check the start-up protection during charging			•	
Function					
32	Test the audio warning signal	•			
33	Check the air gap of the electromagnetic brake	•			
34	Test the emergency braking	•			
35	Test the reverse and regenerative braking	•			
36	Test the safety (belly) button function	•			
37	Check the steering function	•			
38	Check the lifting and lowering function	•			
39	Check the tiller arm switch function	•			
40	Test the key switch of damages and function	•			
41	检测速度限位开关(提升高度 >~600mm)	•			
42	检测速度限位开关(提升高度 >~1800mm)	•			
General					
43	Check if all decals are legible and complete	•			
44	Check if the protective screen and or guarding is not damaged	•			
45	Inspect the castor, adjust the height or replace it, if worn out		•		
46	Carry out a test run	•			

b. Lubricating points

Lubricate the marked points according to the maintenance checklist. The required grease specification is: DIN 51825, standard grease.

1. Load roller bearing
2. Axle
3. Chain
4. Chain wheel
5. Mast
6. Driving wheel gear

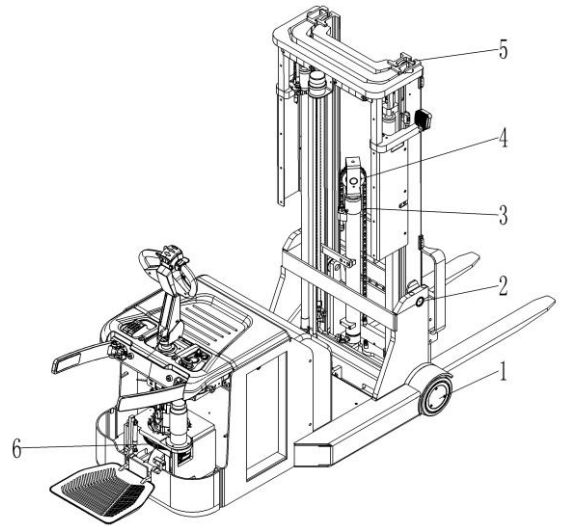

Fig. 14: Lubricating points

c. Check and refill hydraulic oil

It is recommended to use hydraulic oil in connection with average temperature:

Type	H-LP 46, DIN 51524
Viscosity	41.4 - 47
Amount	15L (depends on specific model)

Waste material like oil, used batteries or other must be probably disposed and recycled according to the national regulations and if necessary brought to a recycling company.

The oil level height shall be in the not lifted position min.

If necessary add oil at the filling point.

d. Checking electrical fuses

Remove the main cover. The fuses are located according to Fig. 15; the size is according to table 4.

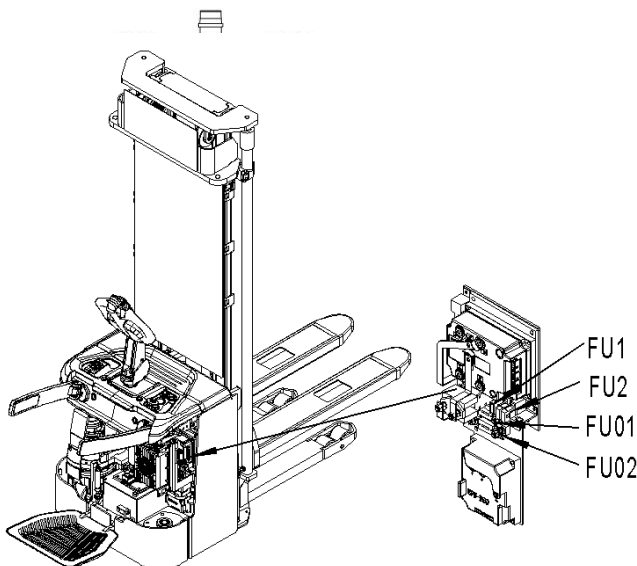

Fig.15: Location of fuses

Table 4: Size of the fuses

	Rate
FU1	10A
FU2	10A
FU3	10A
FU01	350A
FU02	60A

e. Removing, reattaching guarding



DO NOT USE THIS TRUCK, IF THE GUARDING IS DAMAGED OR NOT CORRECTLY ASSEMBLED!

If the guarding needs to be removed - de-attach holding clamps carefully. For reattaching place the screen to its correct position and place holding clamps back to their original position. If you need to replace parts, please call your service partner.

10. TROUBLE SHOOTING



If the truck has malfunctions follow the instructions, mentioned in chapter 6.

Table 5: Trouble shooting

TROUBLE	CAUSE	REPAIR
Load can't be lifted	Load weight too high	Lift only the max. capacity, mentioned on the ID-plate
	Battery discharged	Charge the battery
	Lifting fuse faulty	Check and eventually replace the lifting fuse
	Hydraulic oil level too low	Check and eventually refill hydraulic oil
	Oil leakage	Repair the hoses and/or the sealing of the cylinder
	Lifting stops at ~1800mm	Move the protective arms into the downside position
	Lifting stops at ~1800mm	Check the sensor for the protective arm
	Height sensor for 1800mm height defect	Check the height sensor on the mast
Oil leakage from air breathing	Excessive quantity of oil.	Reduce oil quantity.
Stacker not starts operating	Battery is charging	Charge the battery completely and then remove the main power plug form the electrical socket.
	Battery not connected	Connect the battery correctly
	The fuse is faulty	Check and eventually replace fuses
	Battery discharged	Charge the battery
	Combined emergency switch is activated	De-activate the combined emergency switch by insert and pull the knob.
	Tiller in the operating zone	Move the tiller firstly to the braking zone.

	Protective arms in the upright position, platform folded upright	Move the protective arms into the downside position
	Foldable platform or protective arms in one of the allowed positions	Check the proximate sensors for the arms and platform
	Foldable platform or protective arms not in one of the allowed positions	Check the correct function of the arms and/or platform
Only travelling in one direction	The accelerator and the connections are damaged.	Check the accelerator and the connections.
The stacker only travels very slowly	The battery is discharged.	Check the battery status at the discharge indicator
	The electromagnetic brake is engaged.	Check the electromagnetic brake
	The relating tiller cables are disconnected or damaged	Check the tiller cables and connections.
	Defective height sensor for reduced speed at ~300mm height	Check the sensor
	Electric system overheated	Stop using and cool down the truck
	Defective heat sensor	Check and if necessary replace the heat sensor
The stacker starts up suddenly	The controller is damaged.	Replace the controller.
	The accelerator not moves back to its neutral position.	Repair or replace the accelerator.

If the truck has malfunctions and can't be operated out of the working zone, jack the truck up and go with a load handler under the truck and safe the truck securely. Then move the truck out of the aisle.

11. WIRING/ CIRCUIT DIAGRAM

a. Electrical circuit diagram

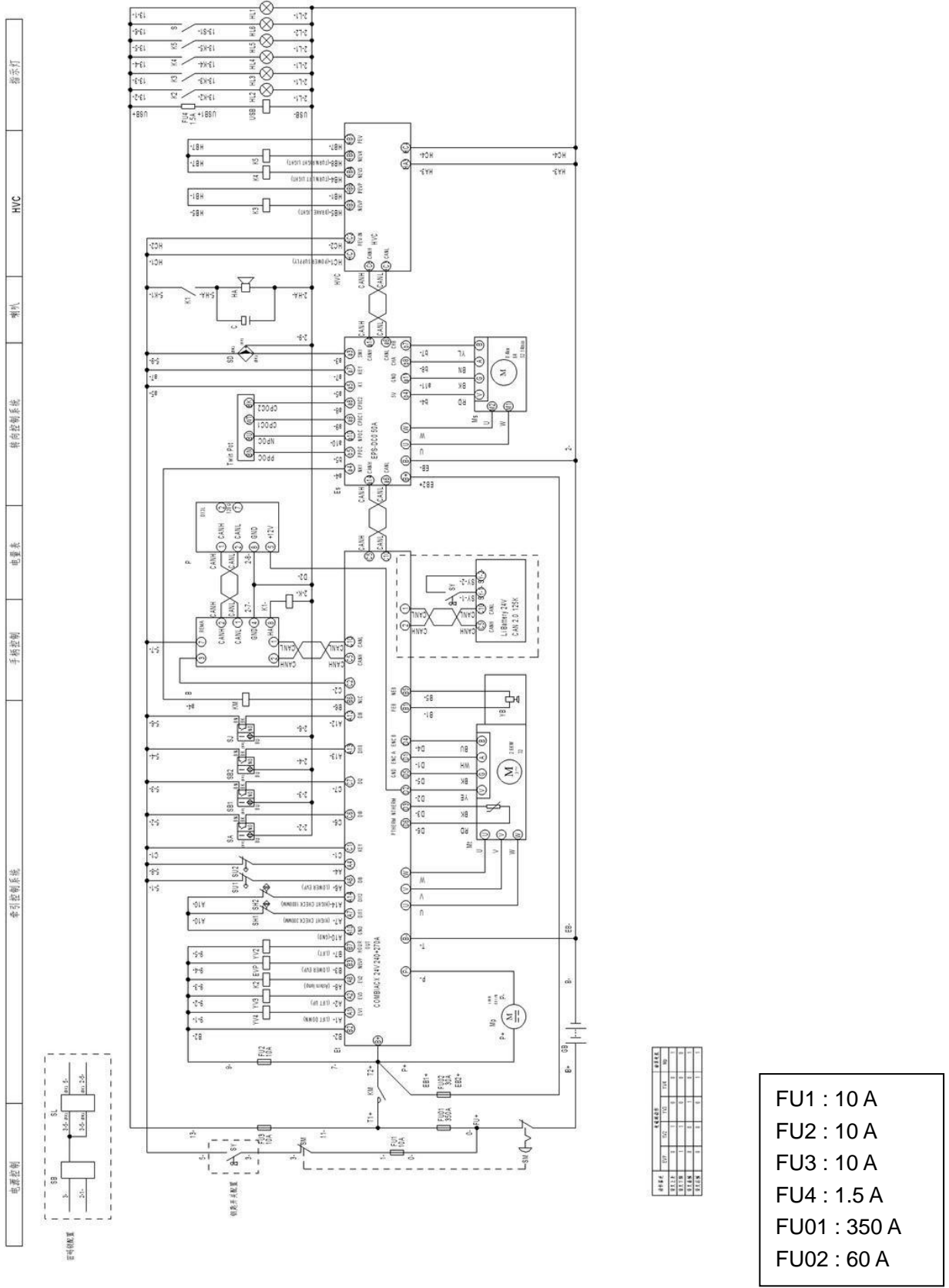

Fig. 16: Electric diagram

Table.6: Code description

Code	Description	Code	Description
B	Tiller	Mp	Pump motor
C	Capacitance	Ms	Steering motor
Es	Steering controller	Mt	Traction motor
Et	Main controller	P	Indicator
EVP	Lowering valve	SA	Interlock switch
FU01	Fuse 350A	SB	Button switch
FU02	Fuse 60A	SB1	Arm switch 1
FU1	Fuse 10A	SB2	Arm switch 2
FU2	Fuse 10A	SD	'0' swich
FU3	Fuse 10A	SH1	Magnetic switch 1
GB	Battery	SH2	Magnetic switch 2
HA	Horn	SJ	Proximity switch of pedal
HL1	Headlamp	SL	Coded lock
HL2	Signal lamp	SM	Emergency switch
HL3	Signal lamp	SU1	Height micro switch
HL4	Signal lamp	SU2	Tilting micro switch
HL5	Signal lamp	SY	Key switch
HL6	Signal lamp	Twin Pot	Double-circuit potentiometer
HVC	Expansion module	USB	USB port
K1	Relay	YB	Magnetic brake
K2	Relay	YV1	Lifting magnetic valve
K3	Relay	YV2	Tilting forward magnetic valve
K4	Relay	YV3	Tilting backward magnetic valve
K5	Relay		
KM	Contactactor		

b. Hydraulic circuit

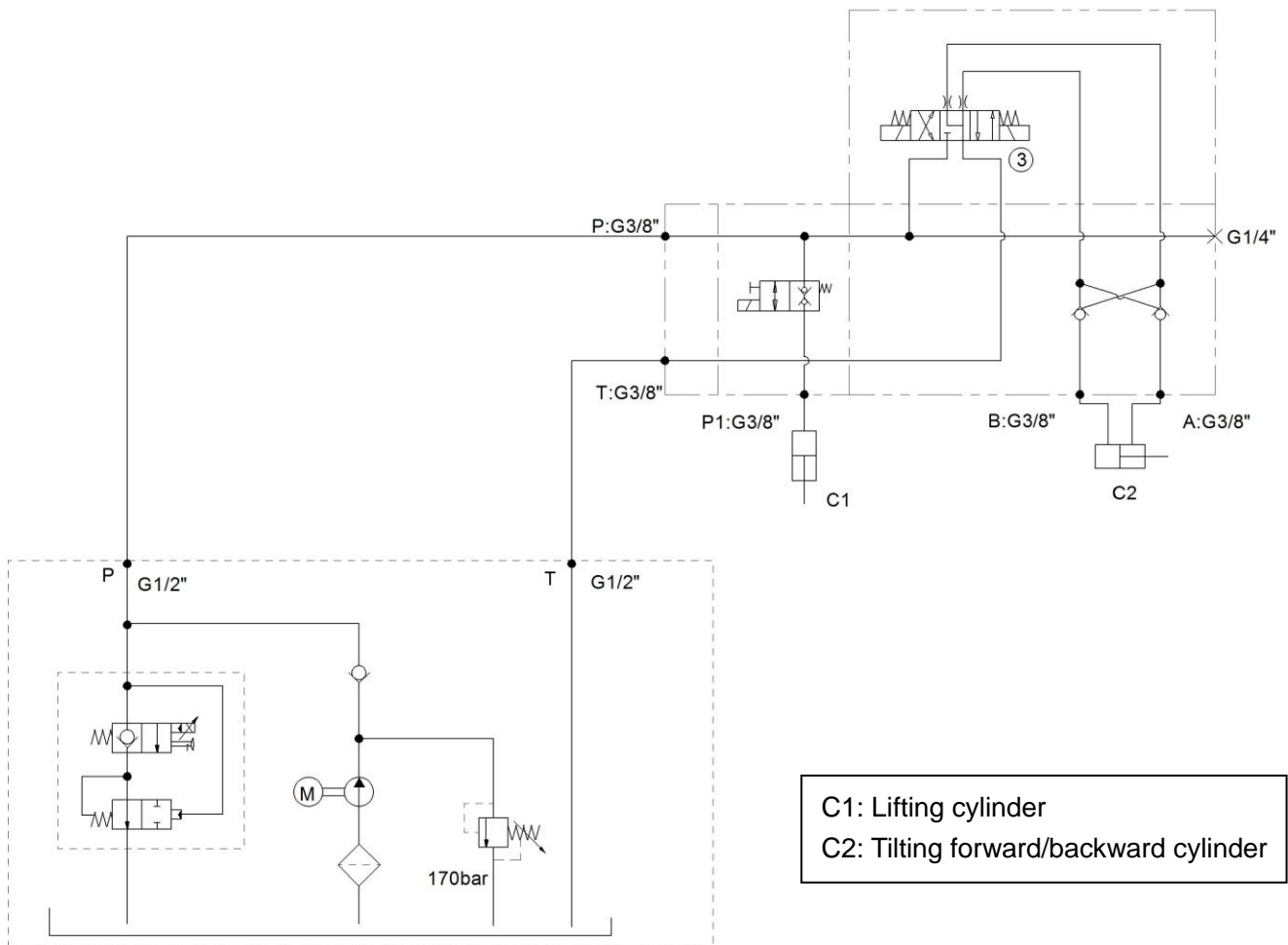

Fig. 17: Hydraulic circuit (HPI)

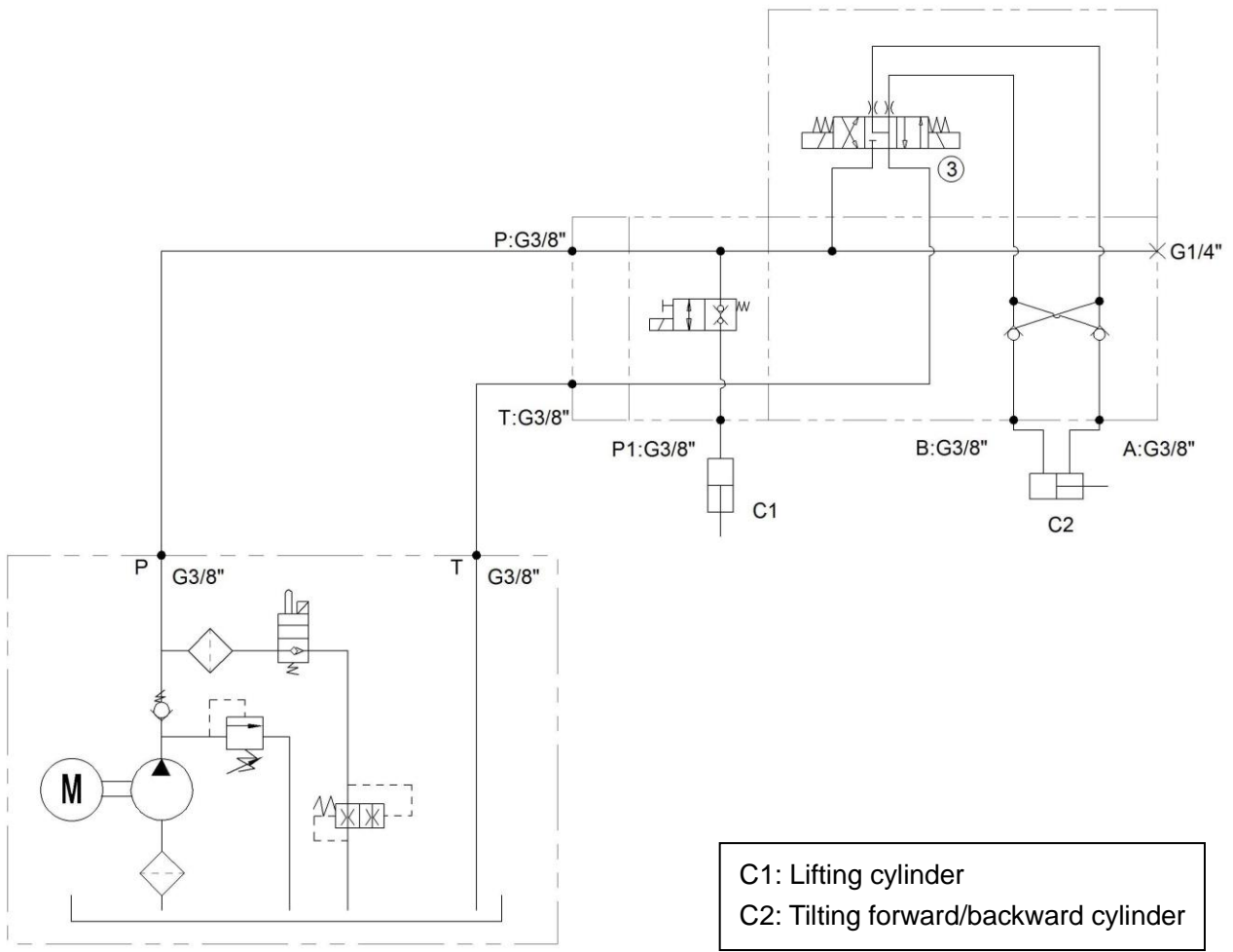

Fig. 18: Hydraulic circuit (VIBO)