

NOBLELIFT

SPAREPARTS LIST

PSCB Electric Stacker (PSCB 12/16/18)

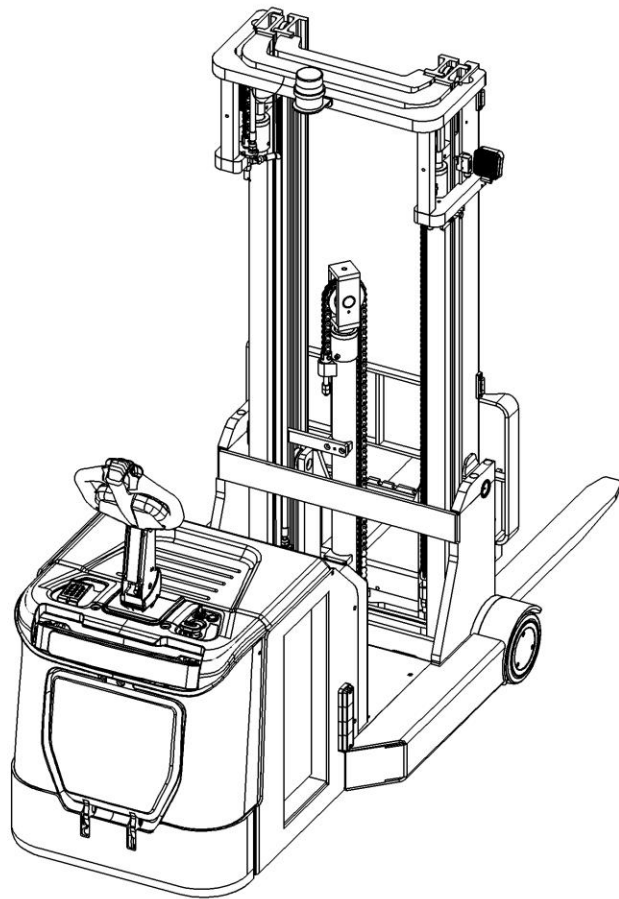

Version 07/2021

From truck identification number:

PSCB 12/16/18-BPT-002-EN

Catalogue

Fig.1 Label (for US).....	1
Fig. 2 Label (For EU)	2
Fig.3 Chassis	3
Fig. 4 Protective arm components	5
Fig. 5 Panel components	7
Fig. 6 Battery cover components	9
Fig.7 Power supply.....	11
Fig.8 Tiller assembly	13
Fig.9 Tiller components	15
Fig. 10 Platform components.....	17
Fig. 11 Roller components	19
Fig. 12 Fork carriage.....	20
Fig.13 Full free lifting three-stage mast.....	21
Fig.14 Standard lifting two-stage mast.....	23
Fig.15 Single mast.....	25
Fig.16 Lifting assembly (full free lifting three-stage mast).....	27
Fig.17 Lifting assembly (standard lifting two-stage mast)	30
Fig.18 Lifting assembly (single mast)	32
Fig.19 Outer cylinder (full free lifting three-stage mast)	34
Fig.20 Middle cylinder (full free lifting three-stage mast).....	36
Fig.21 Outer cylinder (standard lifting two-stage mast).....	38
Fig.22 Middle cylinder (single mast)	40
Fig.23 Driving system	42
Fig.24 EPS components.....	44
Fig.25 Driving assembly	46
Fig.26 Hydraulic system	47
Fig.27 Pump,24V3.2KW4.0cc(HPI)	49
Fig.28 Pump,24V3.0KW3.3cc(VIBO)	50
Fig.29 Work light.....	51
Fig.30 Main circuit wiring harness	53
Fig.31 Electrical control components	54
Easy worn parts list.....	56

Fig.1 Label (for US)

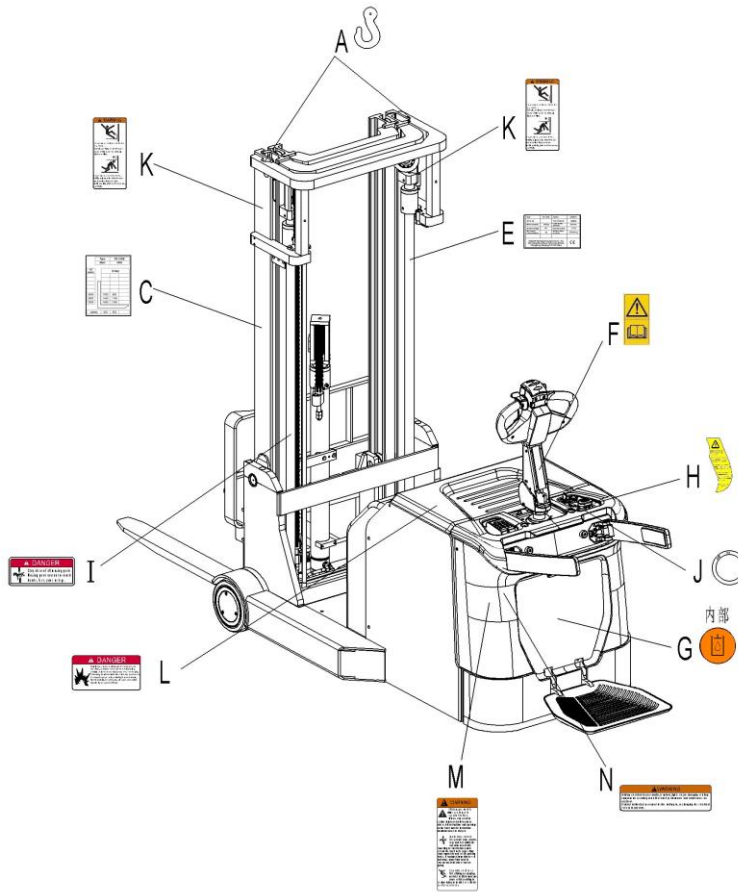

Fig.1 Label (For US)

No.	Art No.	Description	Qty.	Note
A	941200300001	Crane hook label	2	
C	204447520000	Residual lift capacity sticker	1	
E	204447020000	CE label	1	
F	941200300002	Sticker to read and follow these instructions	1	
G	941200300003	Filling sticker	1	
H	941200300018	Warning sticker	1	
I	941200100014	Warning sticker	1	
J	941200400013	Indicating sticker	1	
K	941200100016	Warning sticker	2	
L	941200100013	Warning sticker	1	
M	941200100009	Warning sticker	1	
N	941200100010	Warning sticker	1	

Fig. 2 Label (For EU)

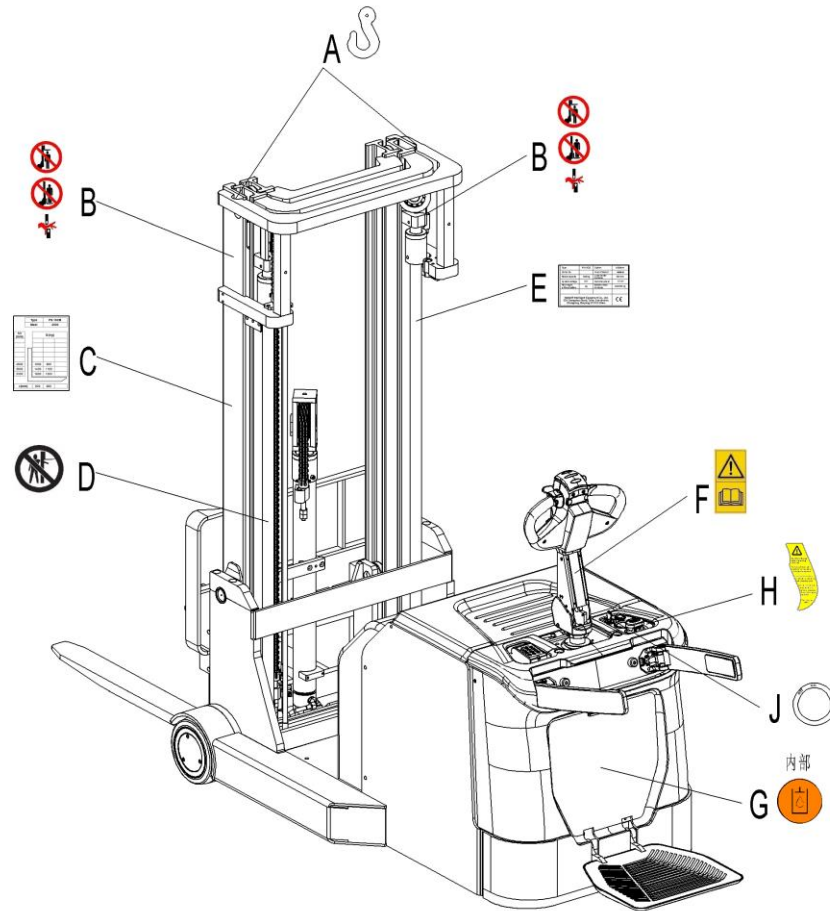

Fig.1 Label (For EU)

No.	Art No.	Description	Qty.	Note
A	941200300001	Crane hook label	2	
B	941200100004	Warning decal: Do not step under or on the forks	2	
C	204447520000	Residual lift capacity sticker	1	
D	941200100006	Never reach through	1	
E	204447020000	CE label	1	
F	941200300002	Sticker to read and follow these instructions	1	
G	941200300003	Filling sticker	1	
H	941200300018	Warning sticker	1	
J	941200400013	Indicating sticker	1	

Fig.3 Chassis

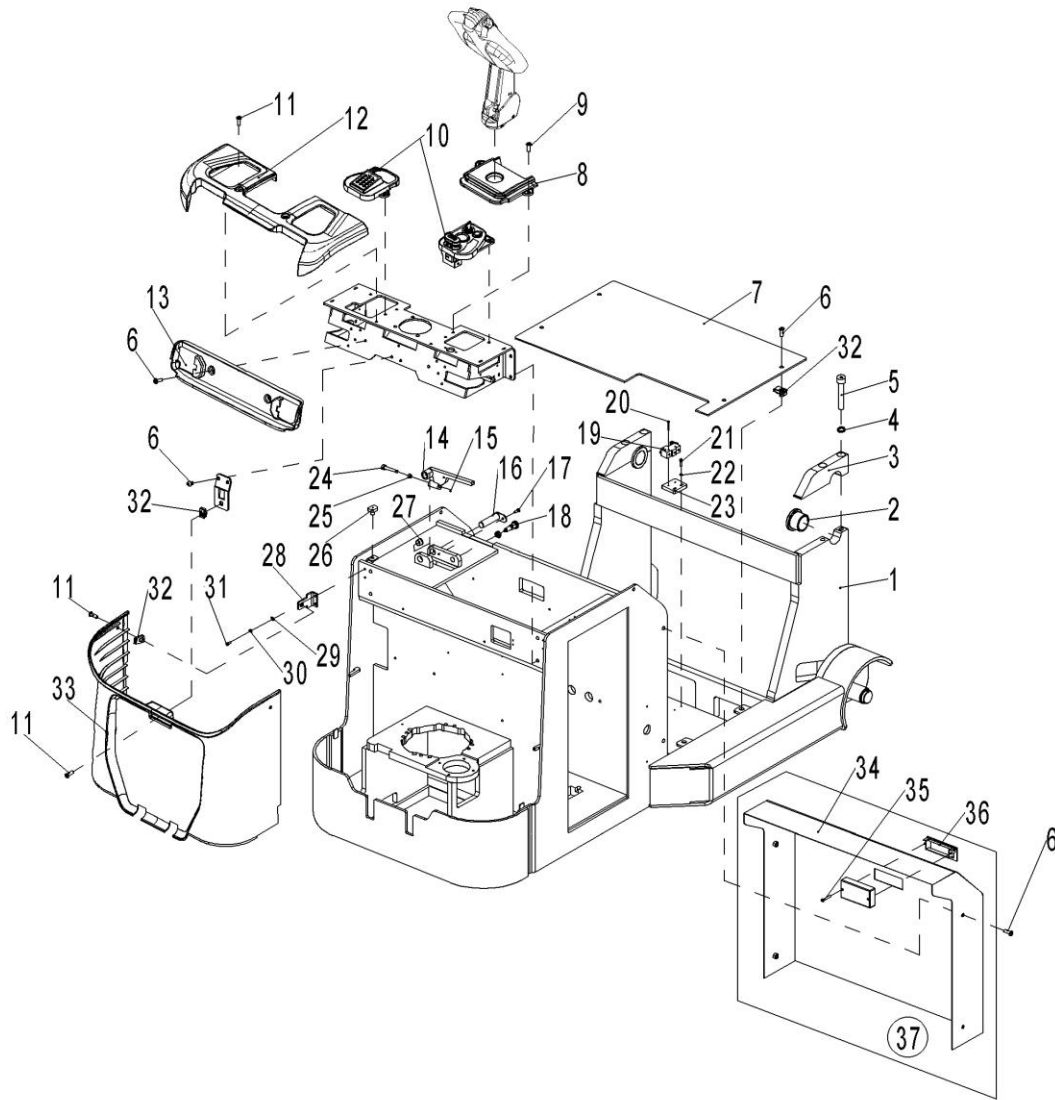

Fig. 3 Chassis

No.	Art No.	Description	Qty.	Note
1	204421510004	Chassis welding	1	PSCB 12
	204421510000	Chassis welding	1	PSCB 16
	204421510003	Chassis welding	1	PSCB 18
2	940500400001	Oilless bearing	2	
3	204421520026	pressing plate	2	
4	910400500010	Spring washer	4	16

5	910200200126	Screw	4	M16x65
6	941100100005	Screw	12	M10x15
7	204421520051	Cover	1	PSCB 12
	204421520027		1	PSCB 16
	204421520042		1	PSCB 18
8	535921520042	Protective cover	1	
9	910200200074	Screw	2	M10x16
10	535910001007	Panel components	1	without pin-code panel
	535910001006	Panel components	1	with pin-code panel
11	941100100004	Screw	5	M10x30
12	535921520040	Protective cover	1	
13	535921520041	Protective cover	1	
14	535921510003	Baffle welding	1	
15	910401300002	Elastic ring	1	10
16	535921510004	Plate with axle	1	
17	910200400017	Screw	1	M6x16
18	940800900002	Pin	1	With nut
19	920200300003	Micro switch	1	
20	910200500016	Screw	2	M3x25
21	910200200016	Screw	2	M4x20
22	910400100003	Flat washer	2	4
23	204424020002	Mounting plate	1	
24	535921520037	Short axle	1	
25	535921520038	Spacer bushing	1	
26	505938520016	Damping pad	1	
27	940500200008	Bushing	2	
28	535921520031	Mounting plate	2	
29	910400100005	Flat washer	13	6
30	910400500005	Spring washer	13	6
31	910200200035	Screw	8	M6x16
32	940400400003	Nut	3	M10
33	535921520039	Protective cover	1	
34	204421510001	Cover welding	1	
35	910200500015	Screw	2	M3x20
36	206521510010	Handle	1	
37	204421510002	Cover components	1	

Fig. 4 Protective arm components

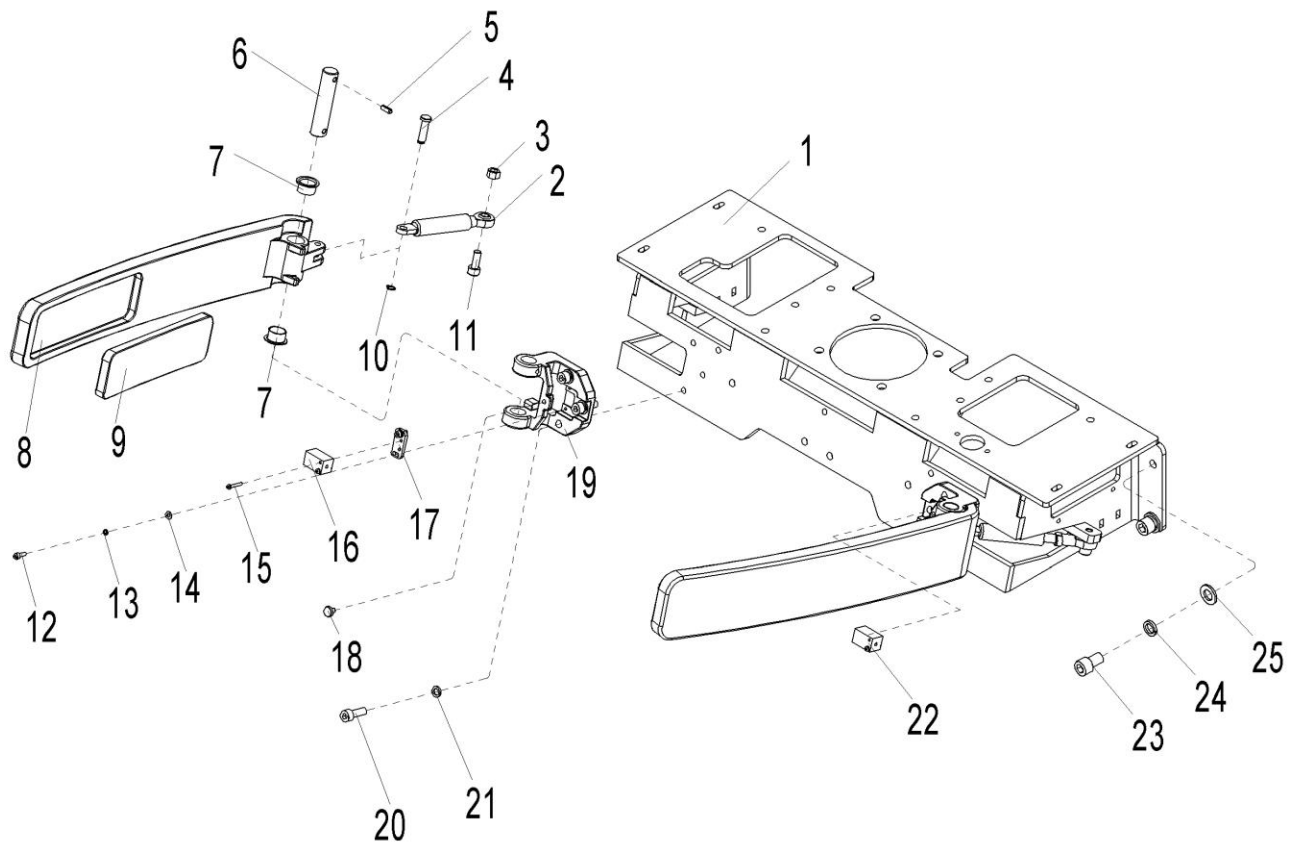

Fig. 7 Protective Arm Components

No.	Art No.	Description	Qty.	Note
1	535917510000	Protective arm mounting base welding	1	
2	940400100037	Air spring	2	250N
3	910300100006	Nut	2	M8
4	535917520010	Axle	2	
5	910600400025	Dowel pin	2	5x30
6	535917520007	Axle	2	
7	940500200003	Bushing	2	
8	535917520008	Protective arm	2	
9	535917520009	Protective pad	2	
10	910401300001	Elastic ring	2	8
11	910200200060	Screw	2	M8x35
12	910200200014	Screw	4	M4x12
13	910400500003	Spring washer	4	4
14	910400100003	Flat washer	4	4
15	910200500015	Screw	4	M3x20
16	505633510002	Proximity switch	1	800mm
17	535917520011	Mounting plate	2	
18	535917520012	Protective pad	2	
19	535917520006	mounting base	2	
20	910200200058	Screw	6	M8x25
21	910400500006	Spring washer	6	8
22	535933510000	Proximity switch	1	420mm
23	910200200096	Screw	4	M12x20
24	910400500008	Spring washer	4	12
25	910400100008	Flat washer	4	12

Fig. 5 Panel components

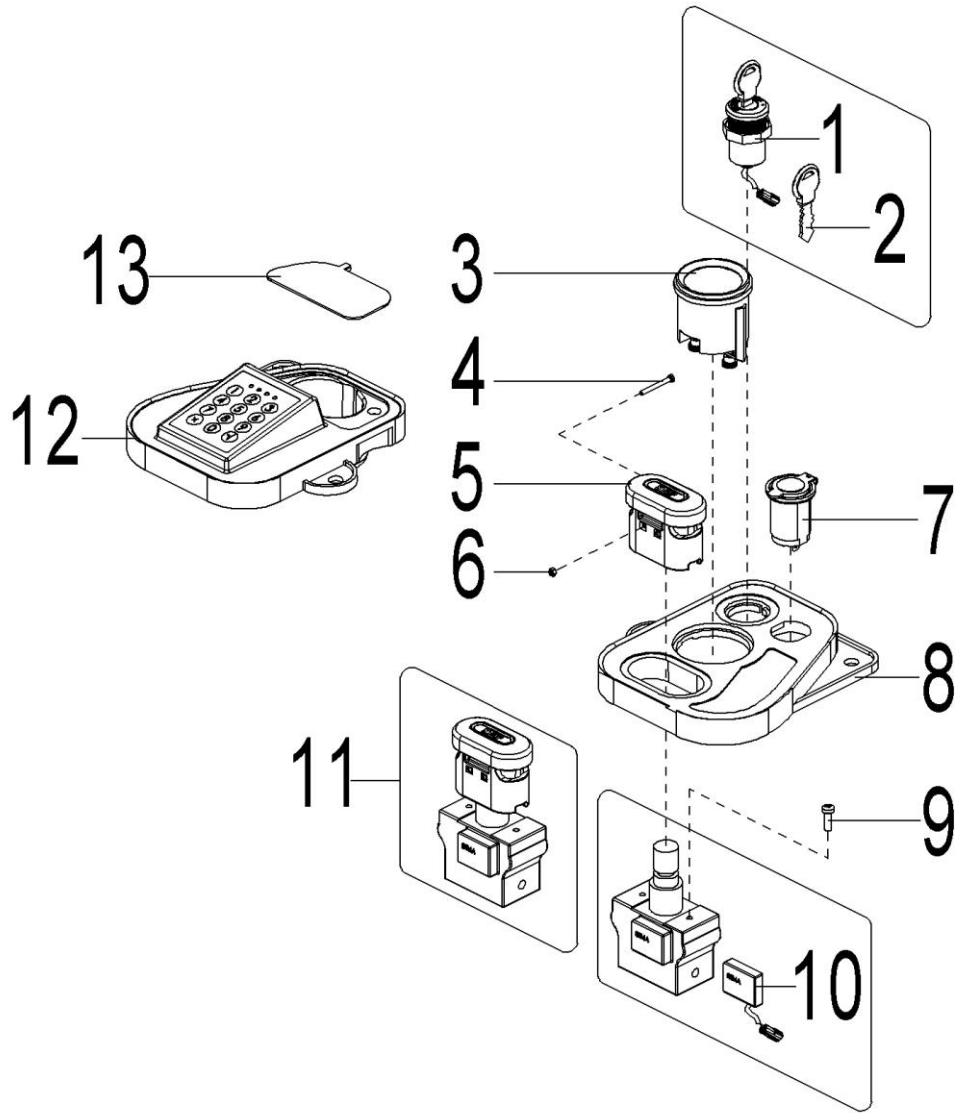

Fig. 5 Panel Components

No.	Art No.	Description	Qty.	Note
1	505634010000	Key switch	1	LKS-101A
	506734010000	Power button switch		
2	920200200001	Key	1	Only for LKS-101A key switch
3	921100100049	Panel	1	D13L
4	910200500017	Screw	2	M3x30
5	920200100006	Mounting base	1	
6	910300100002	Nut	2	M3
7	206033010036	USB port	1	
8	535910020001	Panel (Right)	1	
9	910200500040	Screw	2	M5x16
10	920200100011	Micro switch	1	
11	920200100007	Emergency mounting base	1	ZDK32-350-1
12	535910020004	Panel plate (Left)	1	With pin-code panel
	535910020002	Panel plate (Left)		Without pin-code panel
13	535910020003	Sealing plate	1	

Fig. 6 Battery cover components

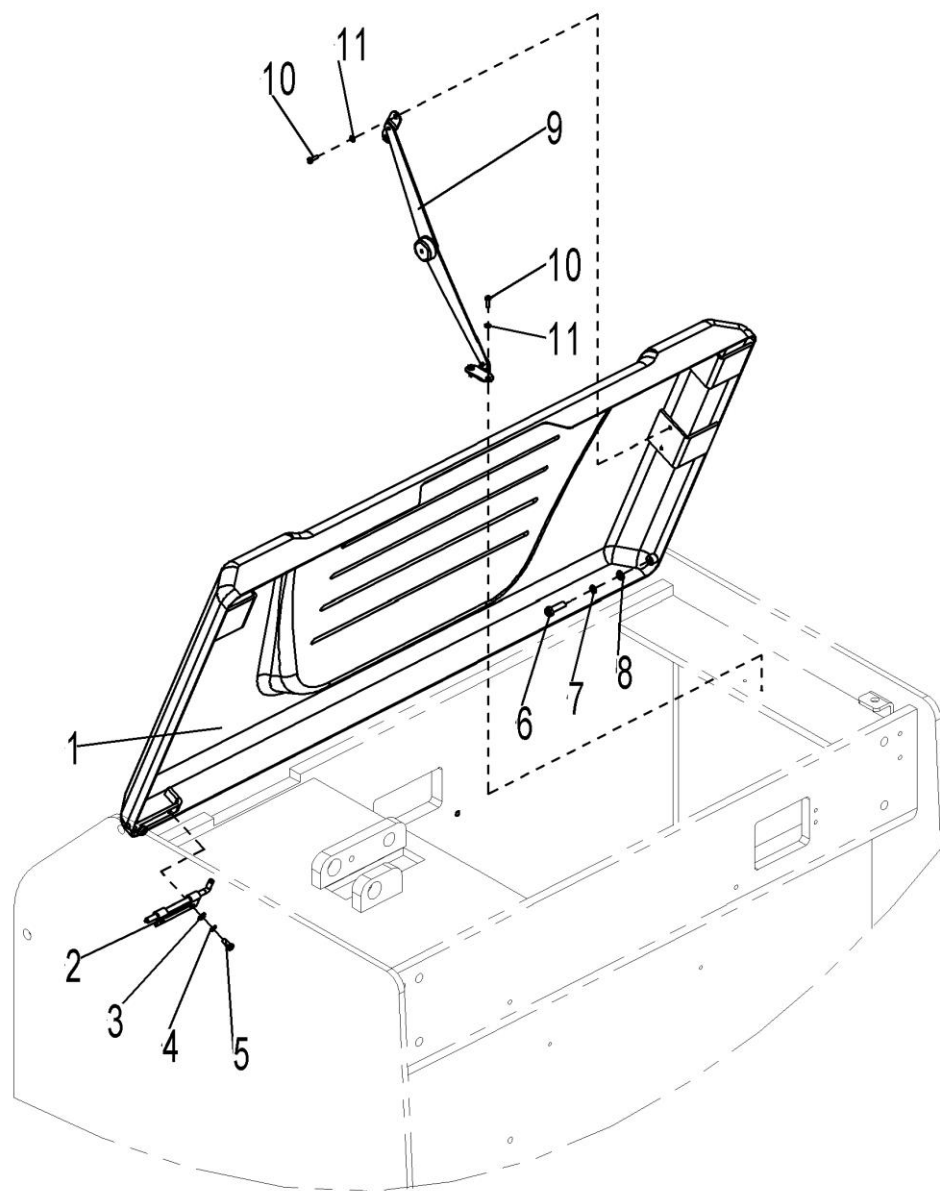

Fig. 6 Battery Cover Components

No.	Art No.	Description	Qty.	Note
1	204421010001	Battery cover welding	1	
2	940800900001	Pin	1	
3	910400100003	Spring washer	2	4
4	910400500003	Flat washer	2	4
5	910200200013	Screw	2	M4x10
6	910200200024	Screw	1	M5x20
7	910400500004	Spring washer	1	5
8	910400100004	Flat washer	1	5
9	206521510003	Position limiter	1	
10	910200300006	Screw	4	M4x10
11	910400500003	Flat washer	4	4

Fig.7 Power supply

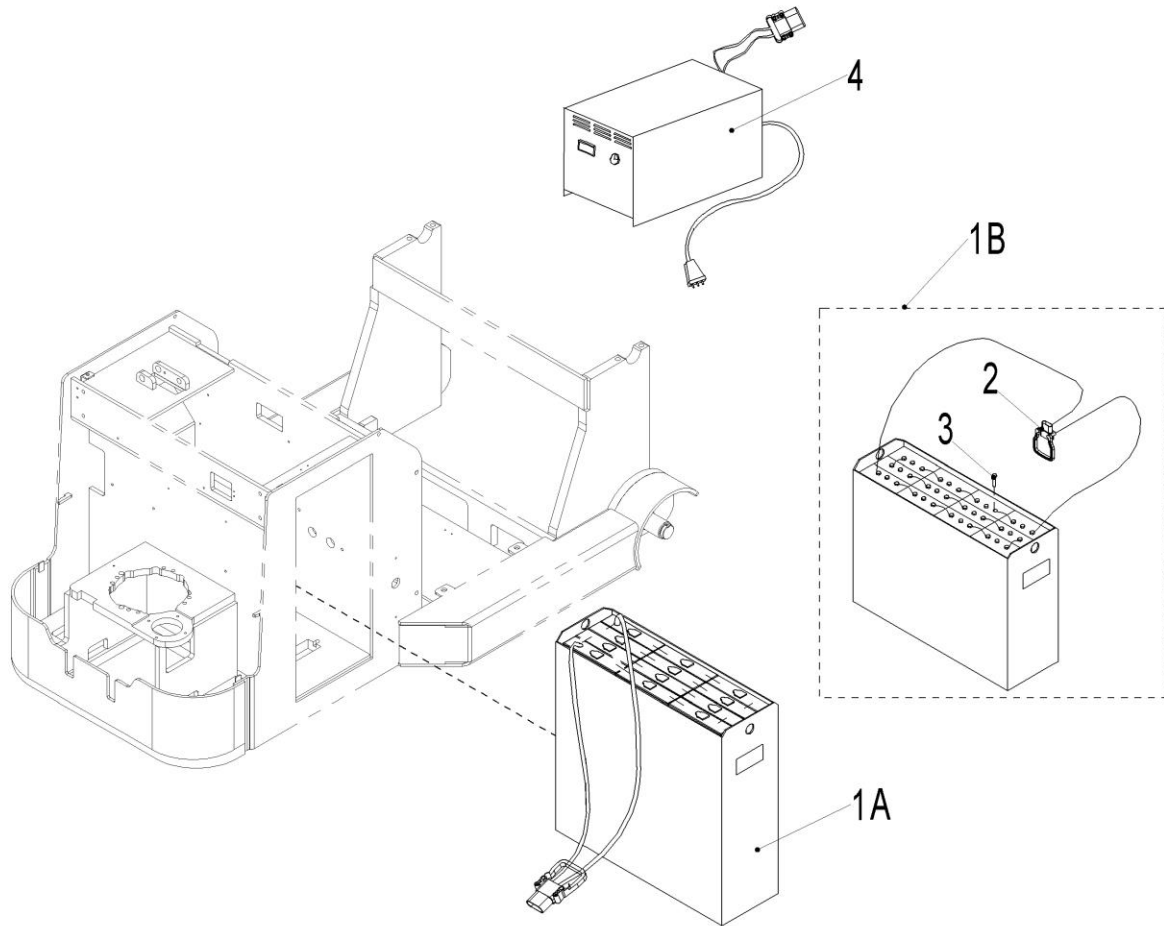

Fig. 7 Power supply

No.	Art No.	Description	Qty.	Note
1A	532937010001	Battery,24V-3PZS270	1	PSCB12/16 Weld type
	532637010002	Battery,24V-3PZS350	1	PSCB18 Weld type
1B	532937010002	Battery,24V-3PZS270	1	PSCB12/16 Bolt type
	532637010003	Battery,24V-3PZS350	1	PSCB18 Bolt type
2	505698510001	Plug components (270Ah)	1	Only for bolt type battery
	532698510008	Plug components (350Ah)	1	
3	505698520000	Screw	24	
4	921000200019	Charger,SN24V45A	1	Asia Chinese
	921000200020	Charger,SN24V45A	1	Asia English
	921000200021	Charger,SN24V45A	1	EU
	921000200022	Charger,SN24V45A	1	AUS
	921000200023	Charger,SN24V45A	1	ENG
	921000200024	Charger,SN24V45A	1	US
	921000200183	Charger,SN24V35A	1	Asia Chinese
	921000200184	Charger,SN24V35A	1	Asia English
	921000200185	Charger,SN24V35A	1	EU
	921000200186	Charger,SN24V35A	1	AUS
	921000200187	Charger,SN24V35A	1	ENG
	921000200188	Charger,SN24V35A	1	US
	921000200365	Charger,SN24V35A	1	ISR
	921000200284	Charger,WT24V35A	1	Asia Chinese
	921000200290	Charger,WT24V35A	1	Asia English
	921000200294	Charger,WT24V35A	1	EU
	921000200302	Charger,WT24V35A	1	AUS
	921000200298	Charger,WT24V35A	1	ENG
	921000200306	Charger,WT24V35A	1	US
	921000200366	Charger,WT24V35A	1	ISR

Note:350Ah with 45A charger, 270Ah with 35A charger.

Fig.8 Tiller assembly

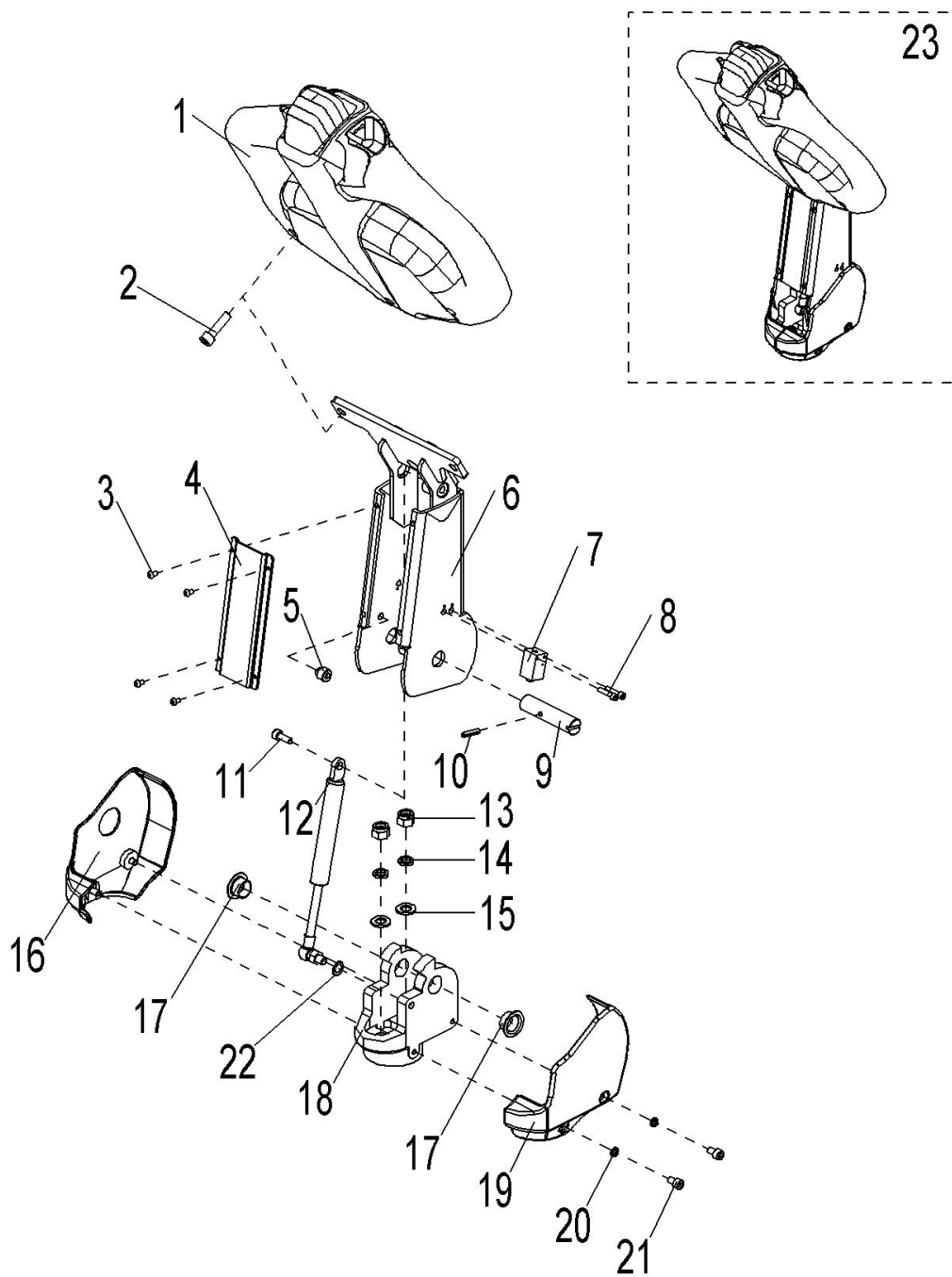

Fig.8 Tiller Assembly

No.	Art No.	Description	Qty.	Note
1	922100100036	Tiller components	1	
2	910200200058	Screw	2	M8x25
3	910200300005	Screw	4	M4x8
4	535911020003	Plate	1	
5	505611020007	Limit screw	1	M8x5
6	535911010000	Tiller welding	1	
7	506733510002	Proximity switch	1	280mm
8	910200500015	Screw	2	M3x20
9	505611020008	Axle	1	
10	910600400013	Dowel pin	1	4x24
11	910200200057	Screw		M8x20
12	940400100001	Air spring	1	330N
13	910300500005	Nut	2	M10
14	910400500007	Spring washer	2	10
15	910400100007	Flat washer	2	10
16	535911020005	Protective cover	1	
17	940500200002	Bushing	2	
18	535911020004	Tiller base	1	
19	535911020006	Protective cover	1	
20	910400500005	Spring washer	2	6
21	910200300016	Screw	2	M6x10
22	910400100006	Flat washer	1	8
23	204411001000	Tiller assembly	1	

Fig.9 Tiller components

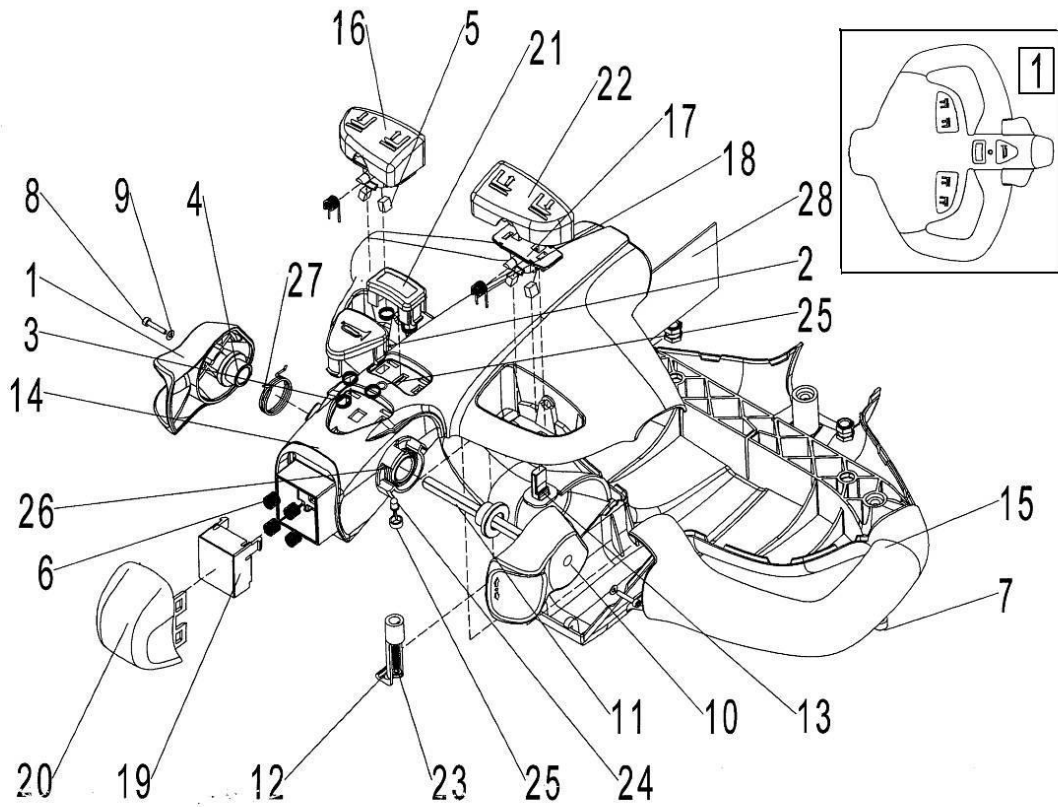

Fig.9 Tiller Components

No.	Art No.	Description	Qty.	Note
1	505698520001	Left driving knob	1	
2	505698520002	Horn	1	
3	505698520003	Spring	5	
4	505698520004	Sleeve	2	
5	505698520005	Magnet	4	
6	505698520006	Spring of emergent reverse button	4	
7	505698520007	Screw	3	M6x10
8	505698520008	Screw	2	M3x16
9	505698520009	Flat pad	2	3
10	505698520010	Right driving knob	1	
11	505698520011	Driving knob Axle	1	
12	505698520012	PCB clip	1	
13	505698520013	Sensor	2	
14	505698520014	Tiller	1	
15	505698520015	Tiller	1	
16	505698520016	Left button	1	
17	505698520017	Magnet fixing base	2	
18	505698520018	Torsional spring	2	
19	505698520019	Emergent reverse button base	1	
20	505698520020	Cover	1	
21	505698520021	Cover	1	
22	505698520022	Right button	1	
23	505698520023	Screw	1	ST4.2x25
24	505698520024	LED bi-color light	1	
25	505698520025	LED bi-color light base	1	
26	505698520026	Right driving knob torsional spring	1	
27	505698520027	Left driving knob torsional spring	1	
28	505698520028	PCB	1	

Fig. 10 Platform components

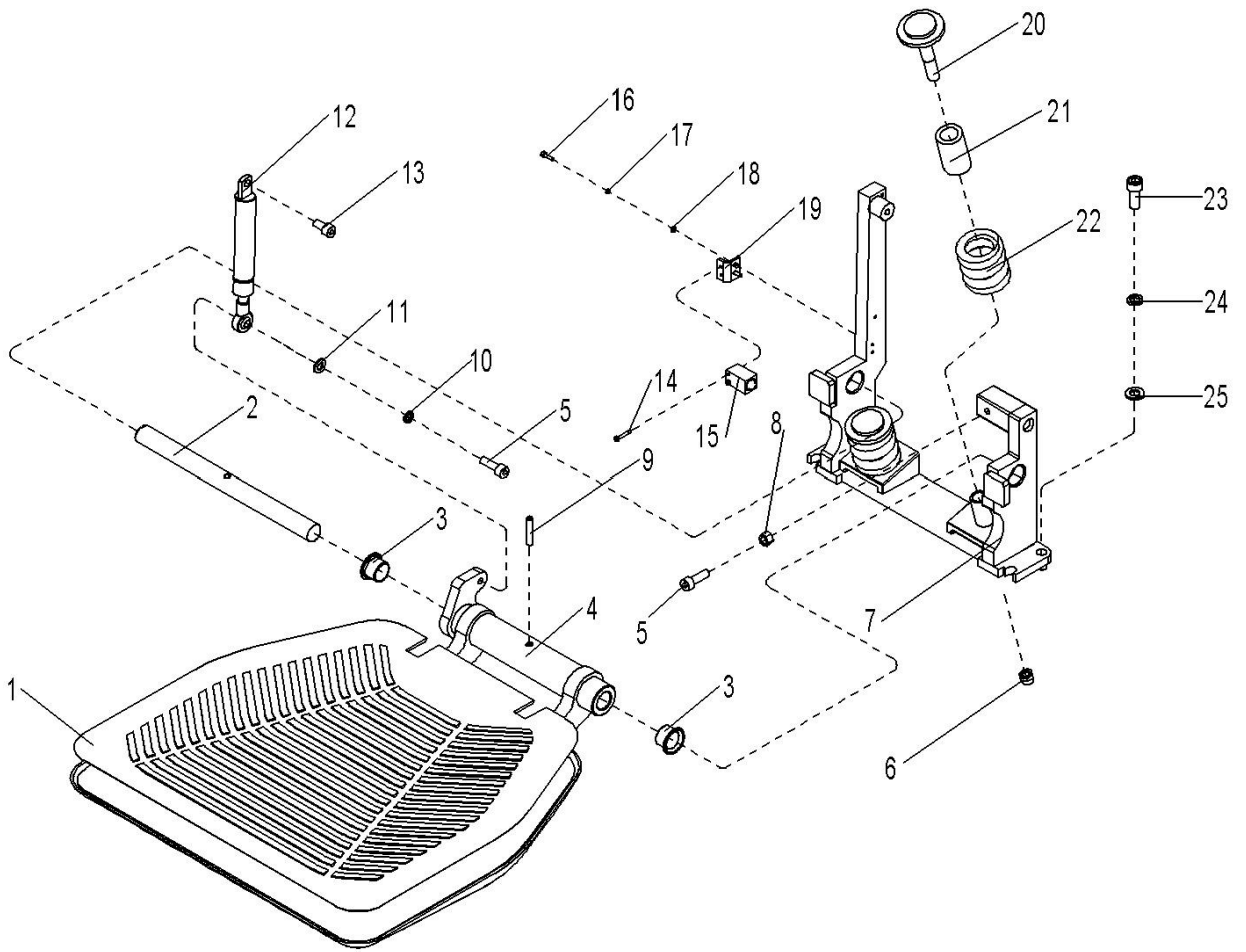

Fig. 10 Platform Components

No.	Art No.	Description	Qty.	Note
1	535918020019	Platform pad	1	
2	535918020014	Axle	1	
3	940500200008	Bushing	2	
4	535918010001	Platform welding	1	
5	910200200058	Screw	2	M8x25
6	910300500006	Nut	2	M12
7	535918010000	Mounting base welding	1	
8	910300100007	Nut	1	M10
9	910600400040	Dowel pin	1	6x35
10	910400500006	Spring washer	1	8
11	910400100006	Flat washer	1	8
12	940400100038	Air spring	1	800N
13	910200200057	Screw	1	M8x20
14	910200500015	Screw	2	M3x20
15	535933510002	Proximity switch	1	Fi5-Q18-OP6L
16	910200200014	Screw	4	M4x12
17	910400500003	Spring washer	4	4
18	910400100003	Flat washer	4	4
19	535918020015	Mounting plate	1	
20	535918020017	Bolt	2	M12x72
21	535918020018	PU bushing	2	
22	535918020016	Spring	2	
23	910200200076	Screw	4	M10x25
24	910400500007	Spring washer	4	10
25	910400100007	Flat washer	4	10
26	506733510005	Proximity switch	1	Fi5-Q18-OP6L
27	535918020022	Mounting plate	1	

Fig. 11 Roller components

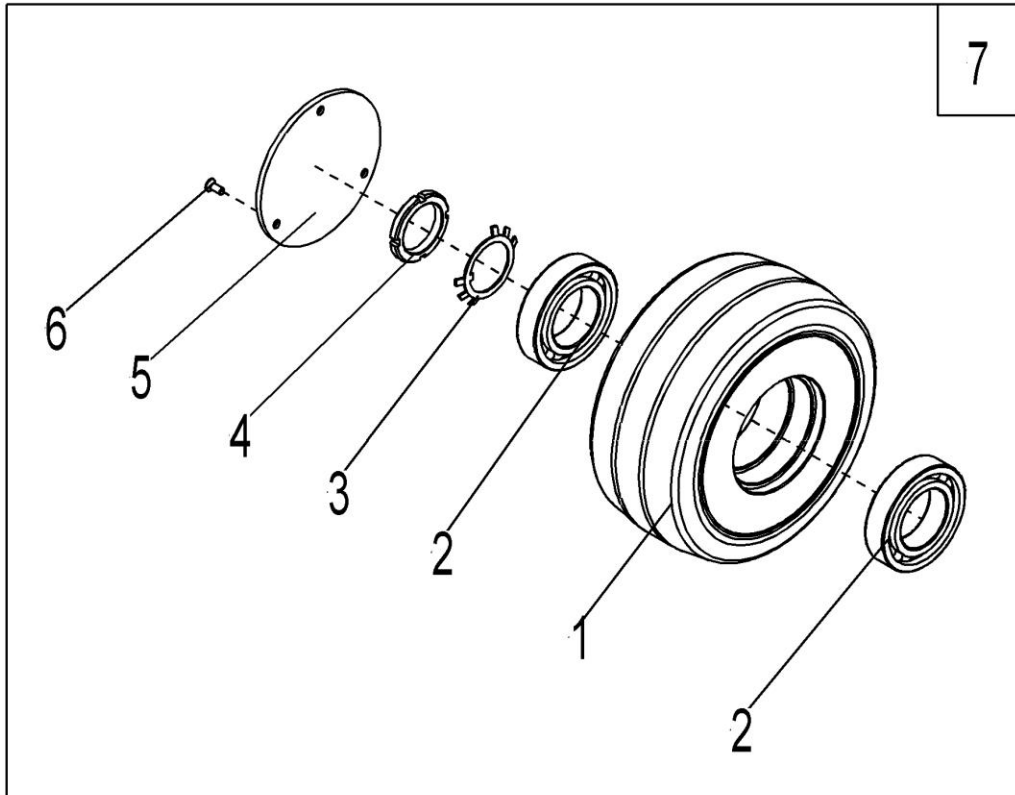

Fig. 11 Roller Components

No.	Art No.	Description	Qty.	Note
1	940300300025	Roller	1	Φ230x100
2	910700200025	Bearing	2	6210
3	910400900010	Lock washer	1	42
4	910300700003	Nut	1	M42x1.5
5	201017020000	End cap	1	
6	910200400016	Screw	3	M6x12
7	202017001000	Roller assembly	1	Φ230x100

Fig. 12 Fork carriage

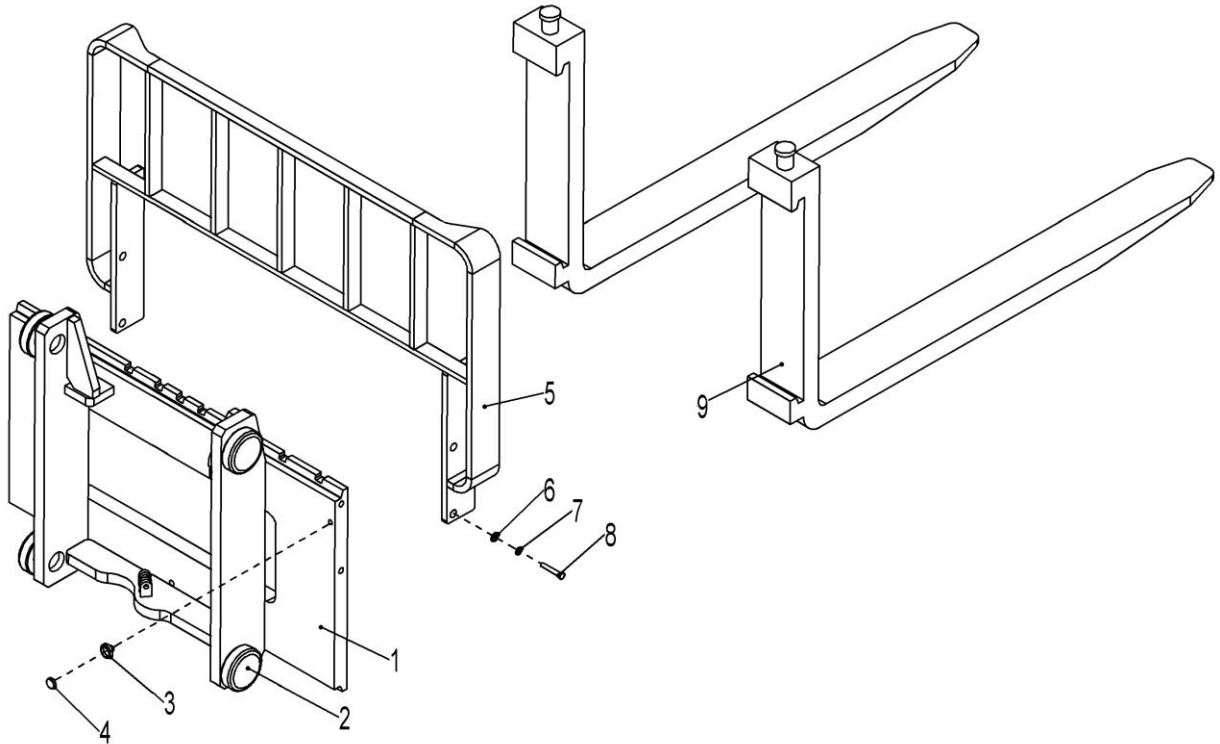

Fig.12 Fork Carriage

No.	Art No.	Description	Qty.	Note
1	204438010000	Fork carriage welding	1	Three-stage mast
	204438010001	Fork carriage welding	1	Two-stage mast
	204438010002	Fork carriage welding	1	Single mast
2	940200300004	Compound roller	4	
3	940600200001	Magnetic steel base	1	
4	940600100001	Magnetic steel	1	
5	216540510000	Load backrest welding	1	
6	910400100008	Flat washer	4	12
7	910400500008	Spring washer	4	12
8	910100300050	Bolt	4	M12x30
9	940100100002	Fork	2	

Fig.13 Full free lifting three-stage mast

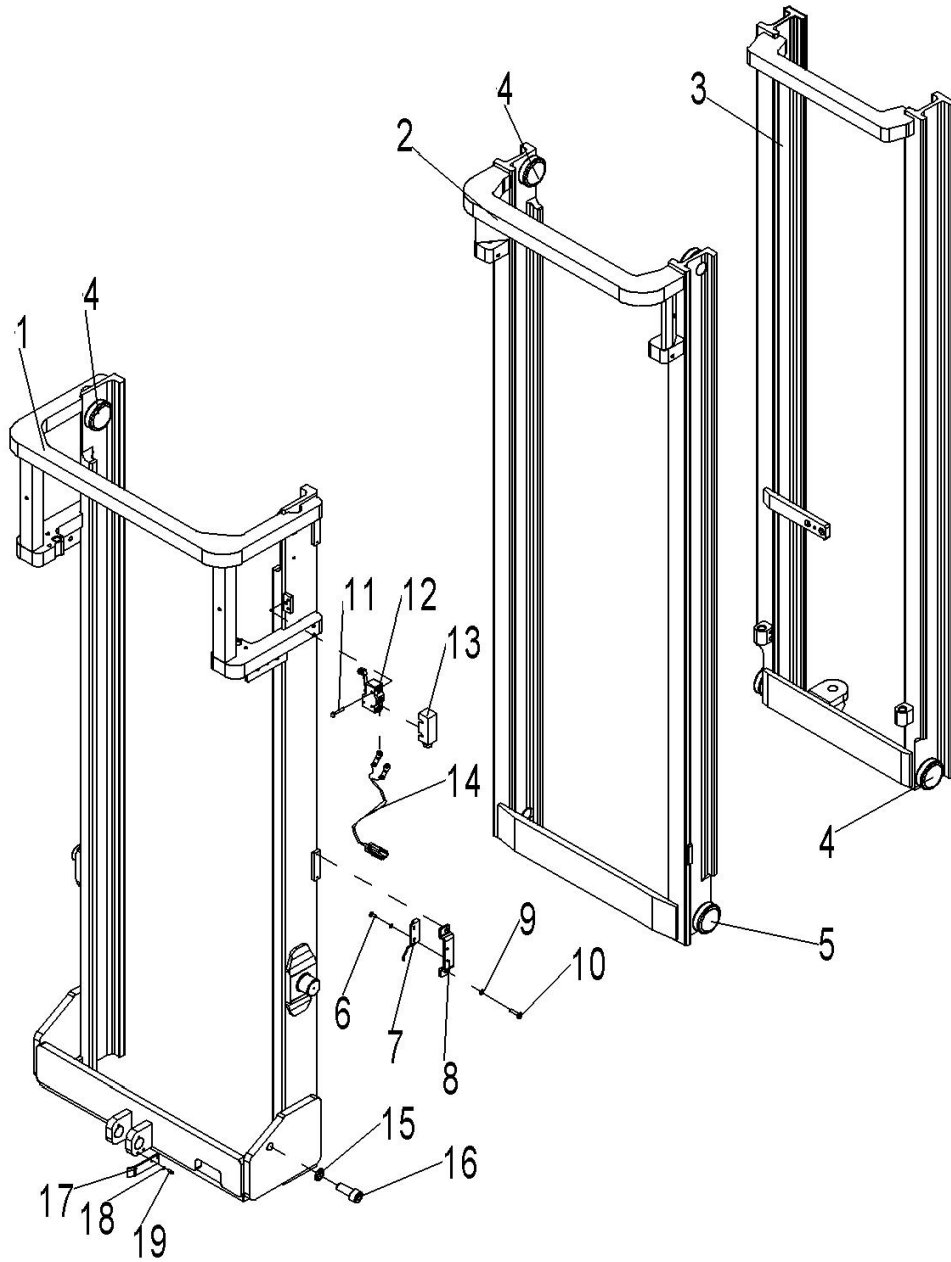

Fig. 13 Full Free Lifting Three-stage Mast

No.	Art No.	Description	Qty.	Note
1	204444510000	External mast	1	4500
	204444510005	External mast	1	4300
	204444510008	External mast	1	4000
	204444510002	External mast	1	3600
2	201044510004	Middle mast	1	4500
	204444510006	Middle mast	1	4300
	204444510009	Middle mast	1	4000
	201044510005	Middle mast	1	3600
3	201044510006	Inner mast	1	4500
	204444510007	Inner mast	1	4300
	204444510010	Inner mast	1	4000
	201044510007	Inner mast	1	3600
4	940200300004	Compound roller	6	
5	940200300007	Compound roller	2	
6	910200500010	Screw	4	M3x8
7	920200500001	Magnetic switch	2	HWK23
8	534744520059	Protective cover	2	
9	910400500003	Spring washer	4	4
10	910200200014	Screw	4	M4x12
11	910200500028	Screw	2	M4x30
12	920200300001	Micro switch	1	XZ-15GW22-B
13	920200300008	Protective cover	1	
14	204433010002	Limit control wiring harness	1	
15	910200200129	Screw	2	M20x30
16	910400500012	Spring washer	2	20
17	204424020003	Plate	1	
18	910400100003	Flat washer	2	4
19	910200200016	Screw	2	M4x20

Fig.14 Standard lifting two-stage mast

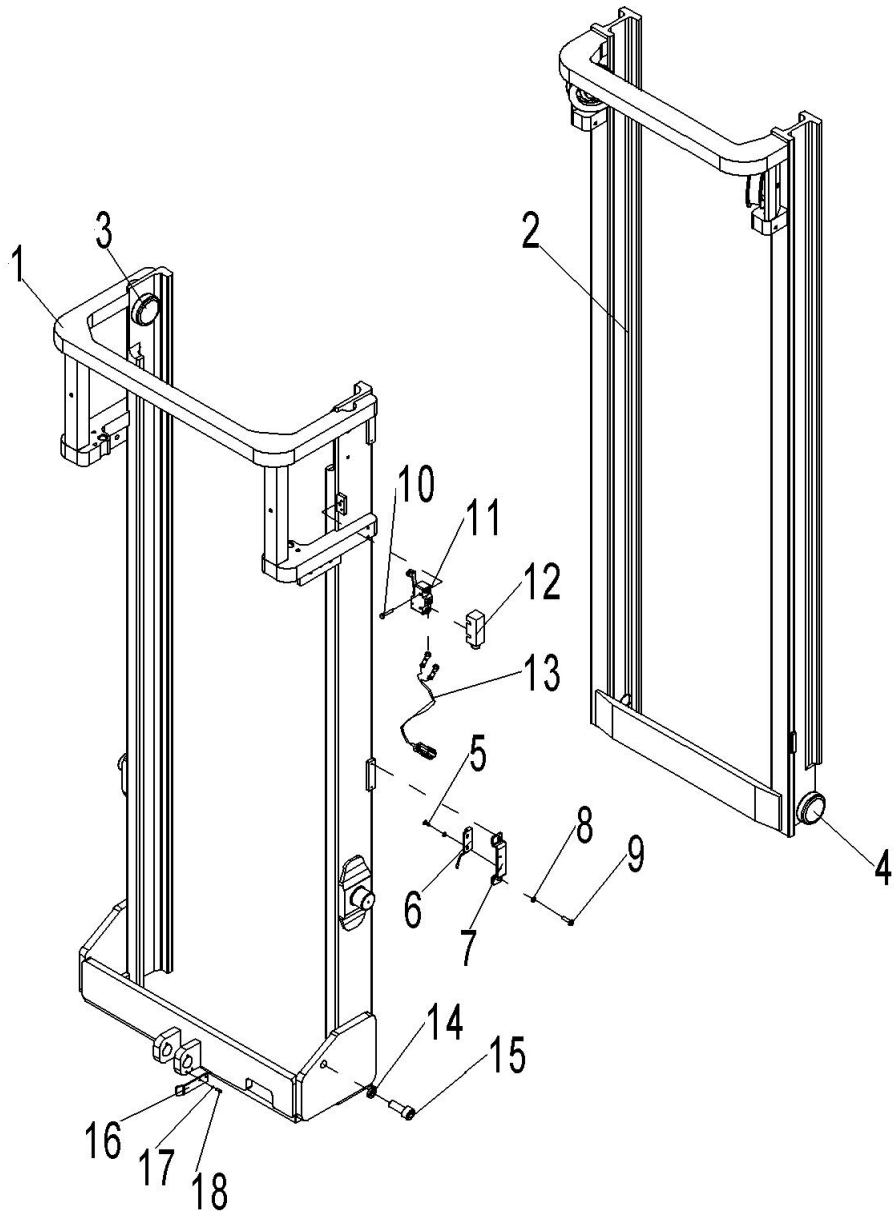

Fig. 14 Standard Lifting Two-stage Mast

No.	Art No.	Description	Qty.	Note
1	204444010009	External mast	1	4000
	204444010006	External mast	1	3600
	204444010003	External mast	1	3200
	204444510000	External mast	1	3000
	204444010000	External mast	1	2500
2	204444010010	Inner mast	1	4000
	204444010007	Inner mast	1	3600
	204444010004	Inner mast	1	3200
	201044010000	Inner mast	1	3000
	204444010001	Inner mast	1	2500
3	940200300004	Compound roller	2	
4	940200300007	Compound roller	2	
5	910200500010	Screw	4	M3x8
6	920200500001	Magnetic switch	2	HWK23
7	534744520059	Protective cover	2	
8	910400500003	Spring washer	4	4
9	910200200014	Screw	4	M4x12
10	910200500028	Screw	2	M4x30
11	920200300001	Micro switch	1	XZ-15GW22-B
12	920200300008	Protective cover	1	
13	204433010002	Limit control wiring harness	1	
14	910200200129	Screw	2	M20x30
15	910400500012	Spring washer	2	20
16	204424020003	Plate	1	
17	910400100003	Flat washer	2	4
18	910200200016	Screw	2	M4x20

Fig.15 Single mast

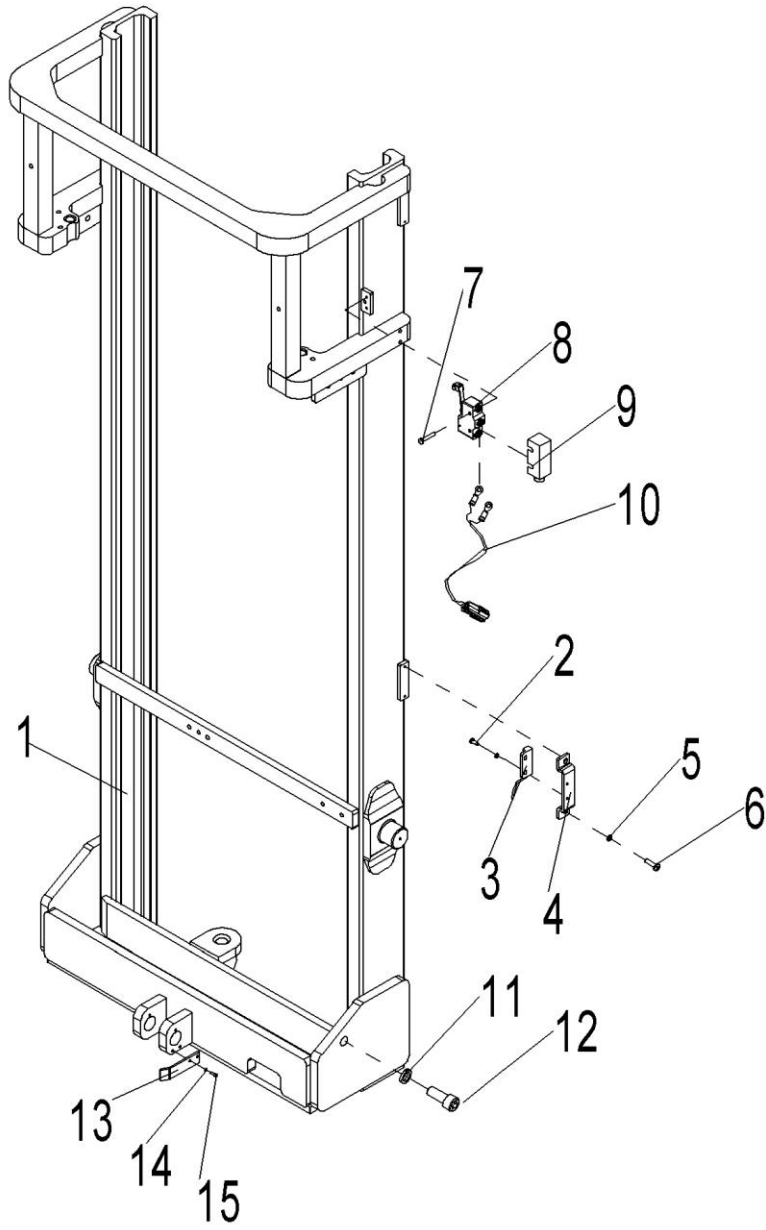

Fig.15 Single mast

No.	Art No.	Description	Qty.	Note
1	204443010000	External mast	1	
2	910200500010	Screw	4	M3x8
3	920200500001	Magnetic switch	2	HWK23
4	534744520059	Protective cover	2	
5	910400500003	Spring washer	4	4
6	910200200014	Screw	4	M4x12
7	910200500028	Screw	2	M4x30
8	920200300001	Micro switch	1	XZ-15GW22-B
9	920200300008	Protective cover	1	
10	204433010002	Limit control wiring harness	1	
11	910200200129	Screw	2	M20x30
12	910400500012	Spring washer	2	20
13	204424020003	Plate	1	
14	910400100003	Flat washer	2	4
15	910200200016	Screw	2	M4x20

Fig.16 Lifting assembly (full free lifting three-stage mast)

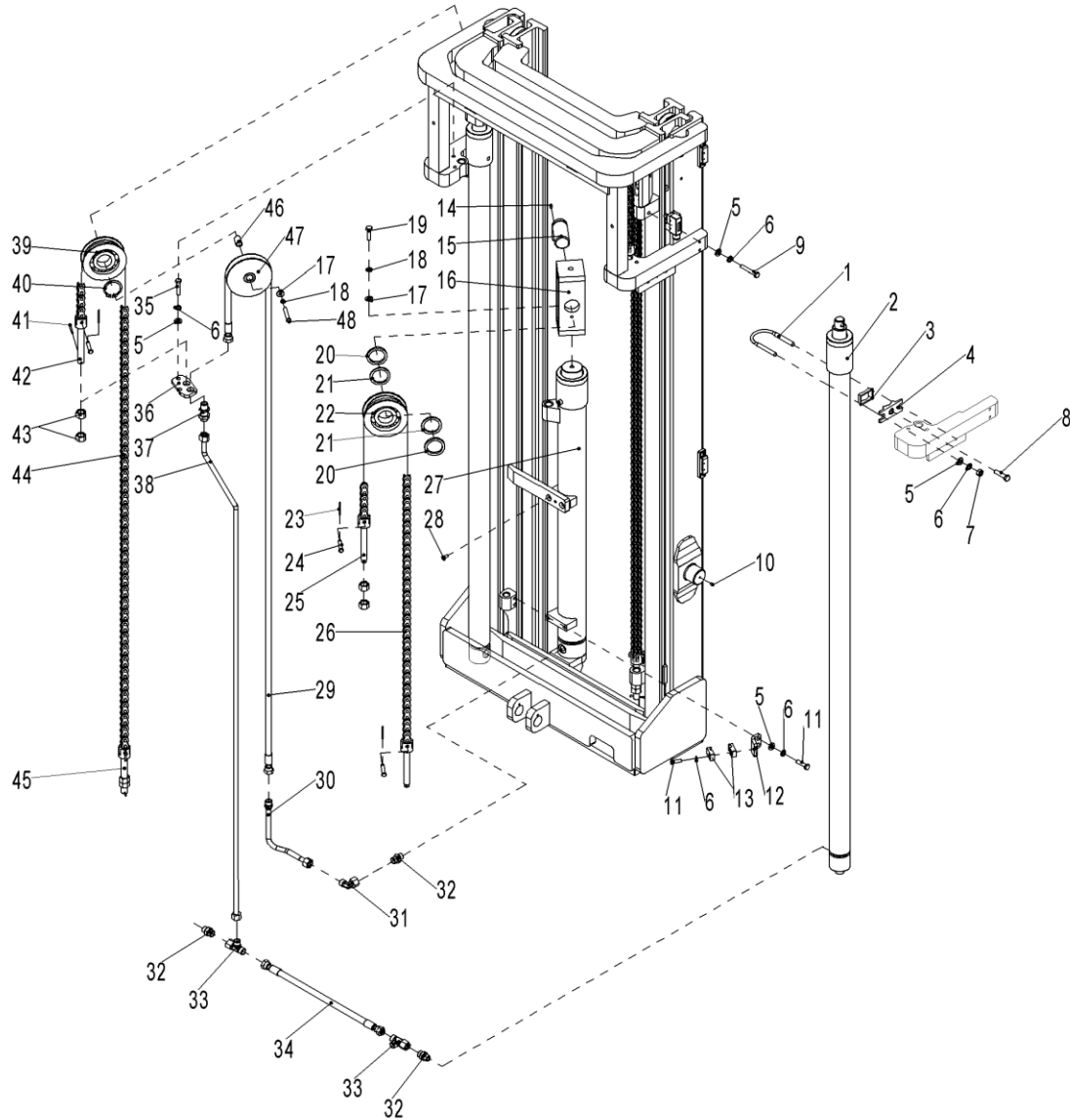

Fig.16 Lifting assembly (full free lifting three-stage mast)

No.	Art No.	Description	Qty.	Note
1	201044520017	U-bolt	2	
2	201044510008	Cylinder	2	4500

	204444510011	Cylinder	2	4300
	204444510013	Cylinder	2	4000
	201044510009	Cylinder	2	3600
3	255044020129	Protective cover	1	
4	255044020130	Fixing seat	2	
5	910400100007	Flat washer	11	10
6	910400500007	Spring washer	12	10
7	910300100007	Nut	6	M10
8	910100300039	Bolt	2	M10x40
9	910100100036	Bolt	2	M10x65
10	911200100001	Grease cup	2	6
11	910200200058	Screw	1	M8x25
12	201044520060	Mounting plate	1	
13	201044520023	Clip	2	12
14	910200400016	Screw	1	M6x12
15	535045010008	Plate with axle	1	
16	204444510003	Wheel carrier	1	
17	910400100008	Flat washer	2	12
18	910400500008	Spring washer	2	12
19	910100300050	Bolt	1	M12x30
20	201044502004	Washer	2	Thickness 2
21	940600500009	Washer	2	Thickness 4
22	940200500011	Chain wheel	1	
23	910600600015	Split pin	6	2x20
24	941100800009	Short axle	2	8x50
25	535045020024	Chain bolt	2	
26	204444510004	Chain,LH1266	1	4500
	204444510021	Chain,LH1266	1	4300
	535044510017	Chain,LH1266	1	4000
	204444510024	Chain,LH1266	1	3600
27	201044510010	Cylinder (M)	1	4500
	204444510012	Cylinder (M)	1	4300
	204444510014	Cylinder (M)	1	4000
	201044510011	Cylinder (M)	1	3600

28	910200400025	Screw	2	M8x20
29	201044520082	Hydraulic Hose	1	4500
	204444510016	Hydraulic Hose	1	4300
	204444510018	Hydraulic Hose	1	4000
	201044520083	Hydraulic Hose	1	3600
30	201044520077	Steel tube	1	
31	950400200004	Joint	1	
32	950400400004	Joint	3	
33	950401000001	Joint	2	
34	201044520086	Hydraulic Hose	1	
35	910200200075	Screw	2	M10x20
36	201044520029	Mounting plate	1	
37	950400500002	Joint	1	
38	204444520026	Steel tube	1	4500
	204444520027	Steel tube	1	4300
	204444520028	Steel tube	1	4000
	204444520029	Steel tube	1	3600
39	940200500001	Chain wheel	2	
40	910401300020	Retainer ring	2	40
41	910600600023	Split pin	6	3x40
42	252044020121	Chain bolt	2	
43	910300200008	Nut	12	M16x1.5
44	201044510017	Chain,LH1234	2	4500
	204444510019	Chain,LH1234	2	4300
	204444510025	Chain,LH1234	2	4000
	201044510019	Chain,LH1234	2	3600
45	535045020024	Chain bolt	2	4500/4000/3600
	252044020121	Chain bolt	2	4300
46	201044520041	Bushing	1	
47	201044520040	Pulley	1	
48	910100300052	Bolt	1	M12x40

Fig.17 Lifting assembly (standard lifting two-stage mast)

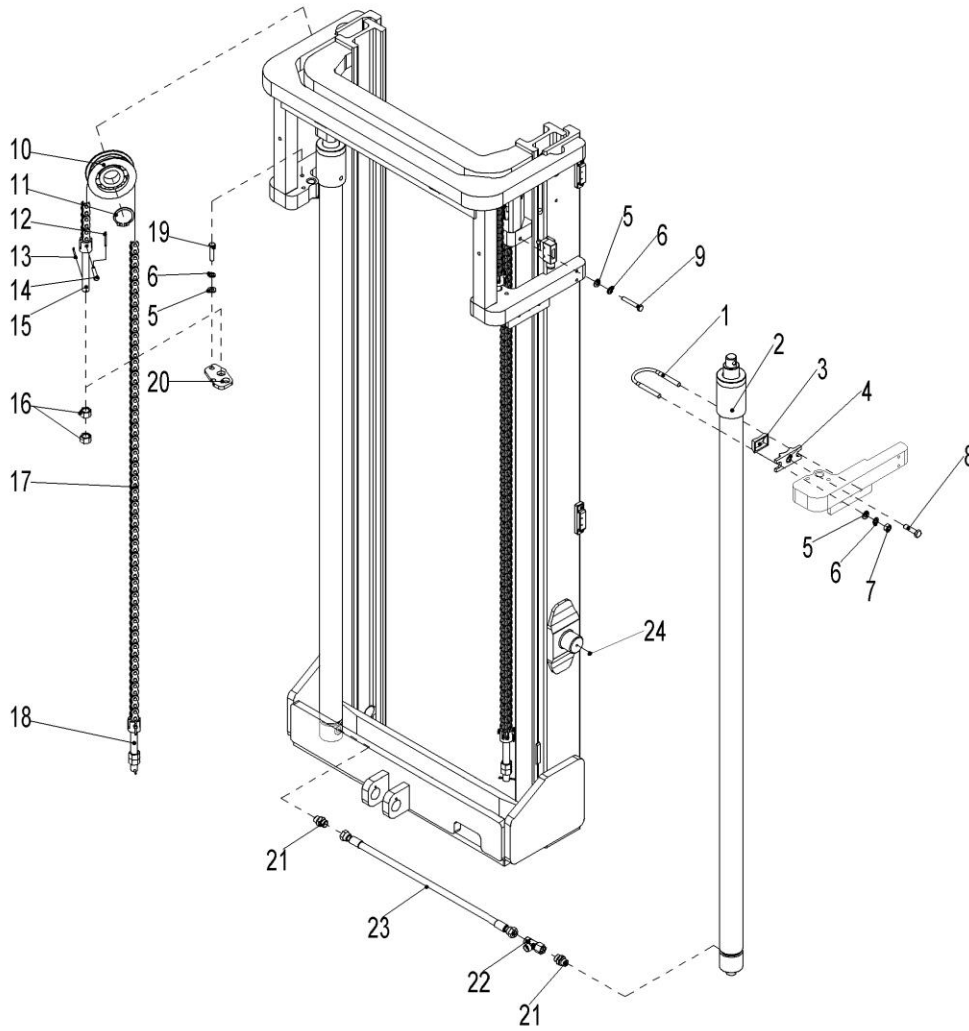

Fig.17 Lifting assembly (standard lifting two-stage mast)

No.	Art No.	Description	Qty.	Note
1	201044520017	U-bolt	2	
2	204444010011	Cylinder	2	4000
	204444010008	Cylinder	2	3600
	204444010005	Cylinder	2	3200

	201044510008	Cylinder	2	3000
	204444010002	Cylinder	2	2500
3	255044020129	Protective cover	1	
4	255044020130	Fixing seat	2	
5	910400100007	Flat washer	11	10
6	910400500007	Spring washer	12	10
7	910300100007	Nut	6	M10
8	910100300039	Bolt	2	M10x40
9	910100100036	Bolt	2	M10x65
10	940200500007	Chain wheel	2	
11	910401300020	Retainer ring	2	40
12	910600600015	Split pin	4	2x20
13	910600600023	Split pin	4	3x40
14	941100800008	Pin	2	8x40
15	252044020121	Chain bolt	2	
16	910300200008	Nut	4	M16x1.5
17	212044510111	Chain,LH1234	2	4000
	204444010012	Chain,LH1234	2	3600
	204444010013	Chain,LH1234	2	3200
	201044510017	Chain,LH1234	2	3000
	204444510019	Chain,LH1234	2	2500
18	533243520008	Chain bolt	2	
19	910200200075	Screw	2	M10x20
20	201044520029	Mounting plate	1	
21	950400400004	Joint	2	
22	950401000001	Joint	1	
23	201044020002	Hydraulic Hose	1	
24	911200100001	Grease cup	2	6

Fig.18 Lifting assembly (single mast)

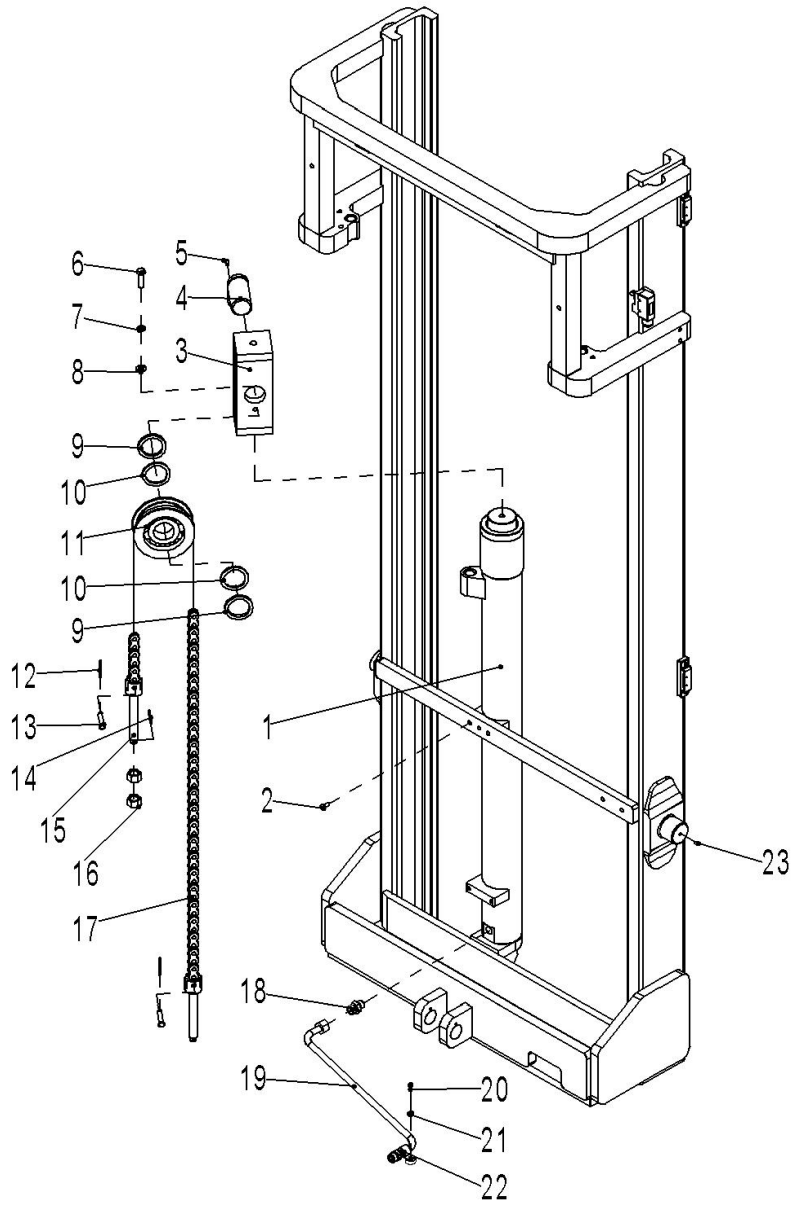

Fig.18 Lifting assembly (single mast)

No.	Art No.	Description	Qty.	Note
1	201043010002	Cylinder(M)	1	
2	910200400026	Screw	2	M8x25
3	204444510003	Wheel carrier	1	
4	535045010008	Plate with axle	1	
5	910200400016	Screw	1	M6x12
6	910100300050	Bolt	1	M12x30
7	910400500008	Spring washer	1	12
8	910400100008	Flat washer	1	12
9	940600500008	Washer	2	Thickness 2
10	940600500009	Washer	2	Thickness 4
11	940200500011	Chain wheel	1	
12	910600600015	Spit pin	2	2x20
13	941100800009	Short axle	2	8x50
14	910600600023	Spit pin	2	3x40
15	535045020024	Chain bolt	2	
16	910300200008	Nut	2	M16x1.5
17	204444510026	Chain,LH1266	1	
18	950400400004	Joint	1	
19	204443010001	Steel tube	1	
20	910200200032	Screw	1	M6x10
21	910400100005	Flat washer	1	6
22	951000100001	Rubber clip	1	12
23	911200100001	Grease cup	2	6

Fig.19 Outer cylinder (full free lifting three-stage mast)

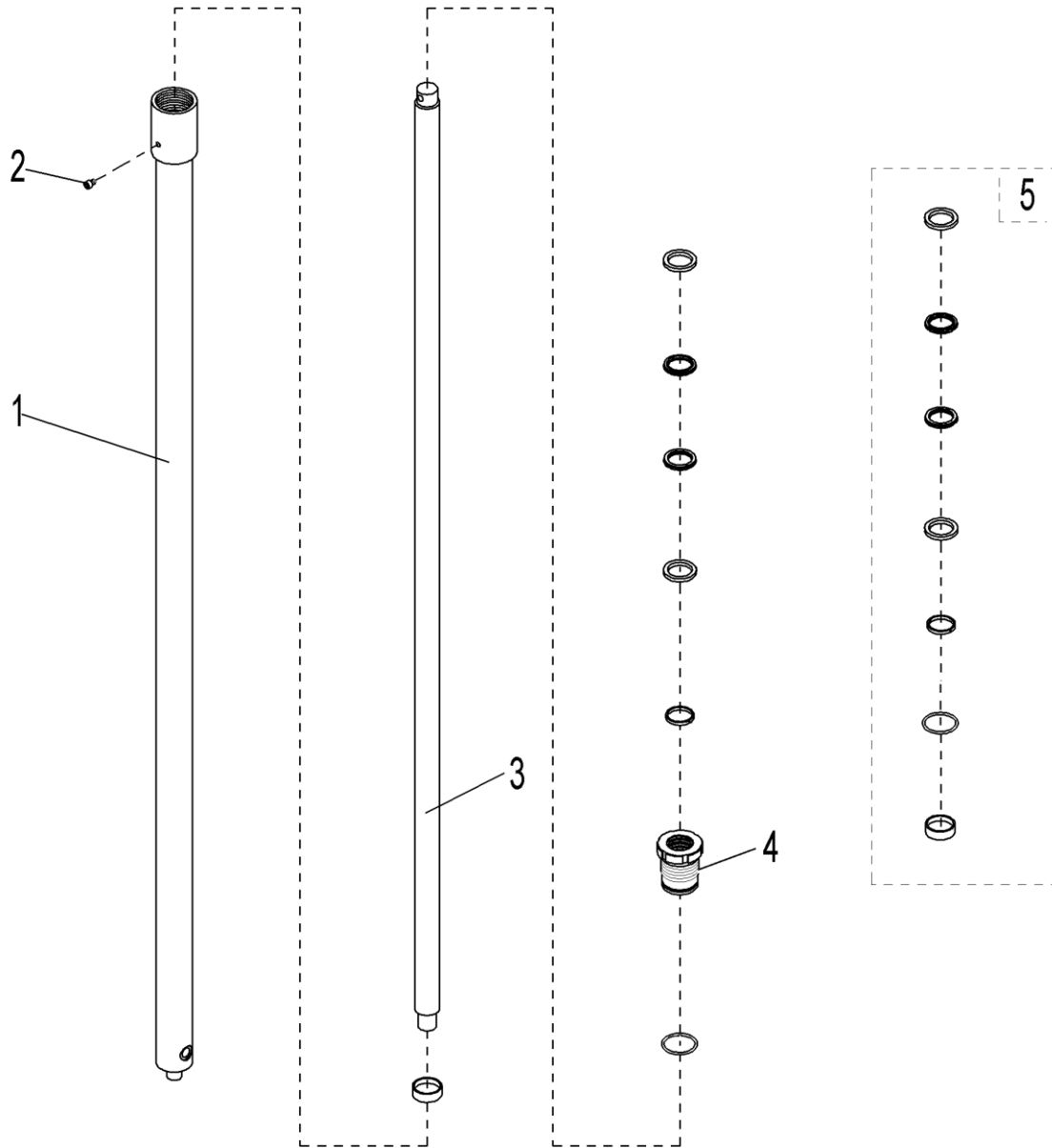

Fig.19 Outer cylinder (full free lifting three-stage mast)

No.	Art No.	Description	Qty.	Note
1	201098520030	Cylinder tube	1	4500
	204498520000	Cylinder tube	1	4300
	204498520001	Cylinder tube	1	4000
	201098520031	Cylinder tube	1	3600
2	201098520032	Screw	1	M8x1
3	201098520034	Piston rod	1	4500
	204498520002	Piston rod	1	4300
	204498520003	Piston rod	1	4000
	201098520035	Piston rod	1	3600
4	201098520037	End cap	1	
5	201098510005	Sealing components	1	

Fig.20 Middle cylinder (full free lifting three-stage mast)

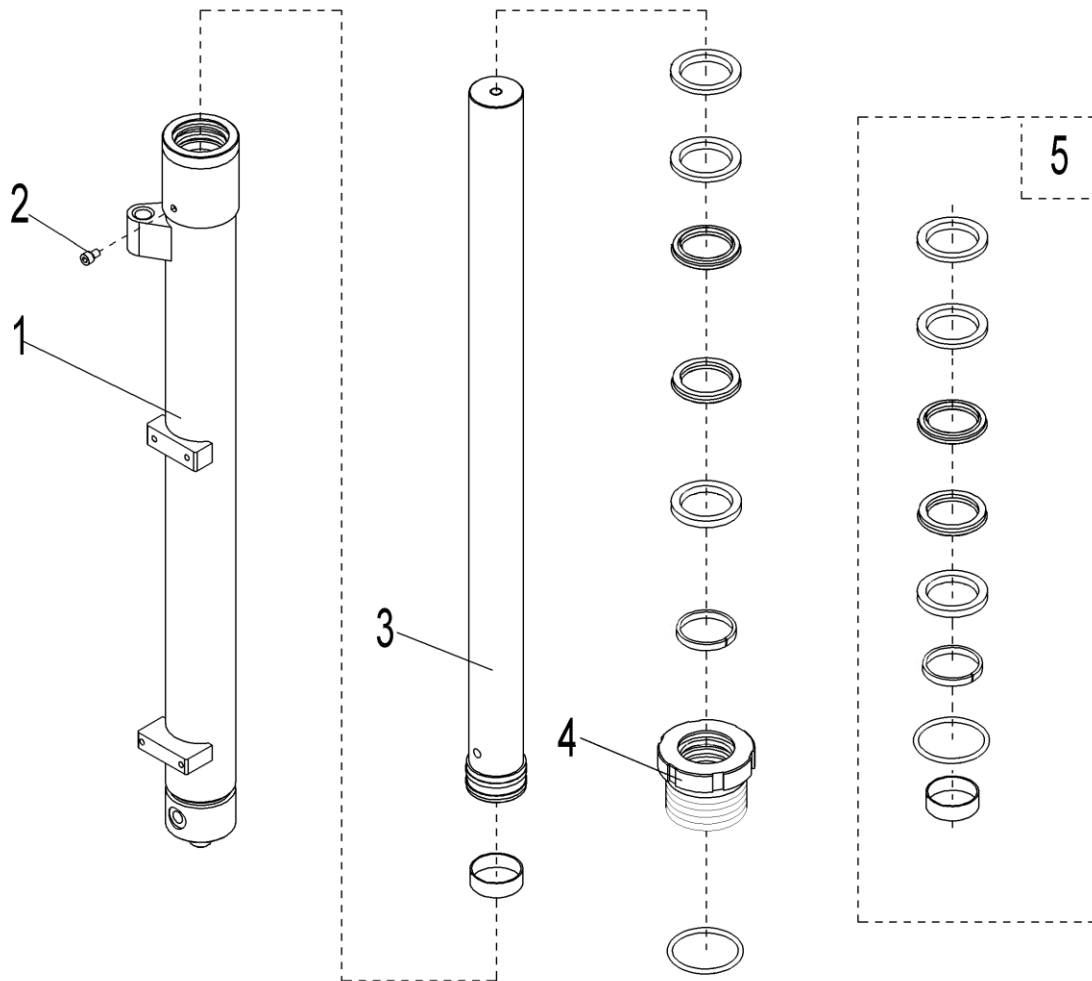

Fig.20 Middle cylinder (full free lifting three-stage mast)

No.	Art No.	Description	Qty.	Note
1	201098520043	Cylinder tube	1	4500
	204498520004	Cylinder tube	1	4300
	204498520005	Cylinder tube	1	4000
	204498520009	Cylinder tube	1	3600
2	201098520032	Screw	1	M8x1
3	201098520048	Piston rod	1	4500
	204498520006	Piston rod	1	4300
	204498520007	Piston rod	1	4000
	201098520049	Piston rod	1	3600
4	201098520053	End cap	1	
5	201098510006	Sealing components	1	

Fig.21 Outer cylinder (standard lifting two-stage mast)

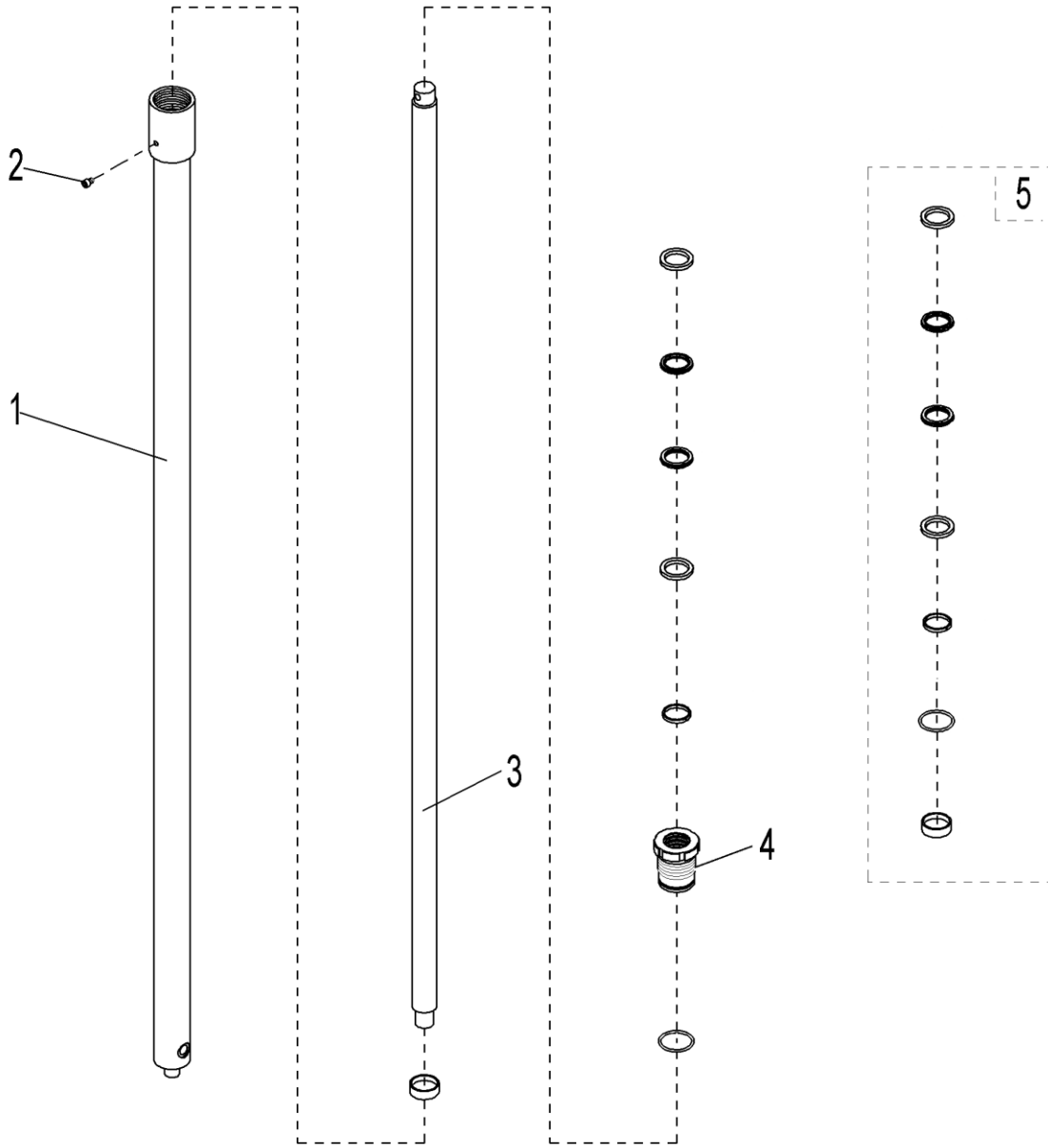

Fig.21 Outer cylinder (standard lifting two-stage mast)

No.	Art No.	Description	Qty.	Note
1	204498520008	Cylinder tube	1	4000
	204498520009	Cylinder tube	1	3600
	204498520010	Cylinder tube	1	3200
	201098520030	Cylinder tube	1	3000
	204498520011	Cylinder tube	1	2500
2	201098520032	Screw	1	M8x1
3	204498520012	Piston rod	1	4000
	204498520013	Piston rod	1	3600
	204498520014	Piston rod	1	3200
	201098520034	Piston rod	1	3000
	204498520015	Piston rod	1	2500
4	201098520053	End cap	1	
5	201098510005	Sealing components	1	

Fig.22 Middle cylinder (single mast)

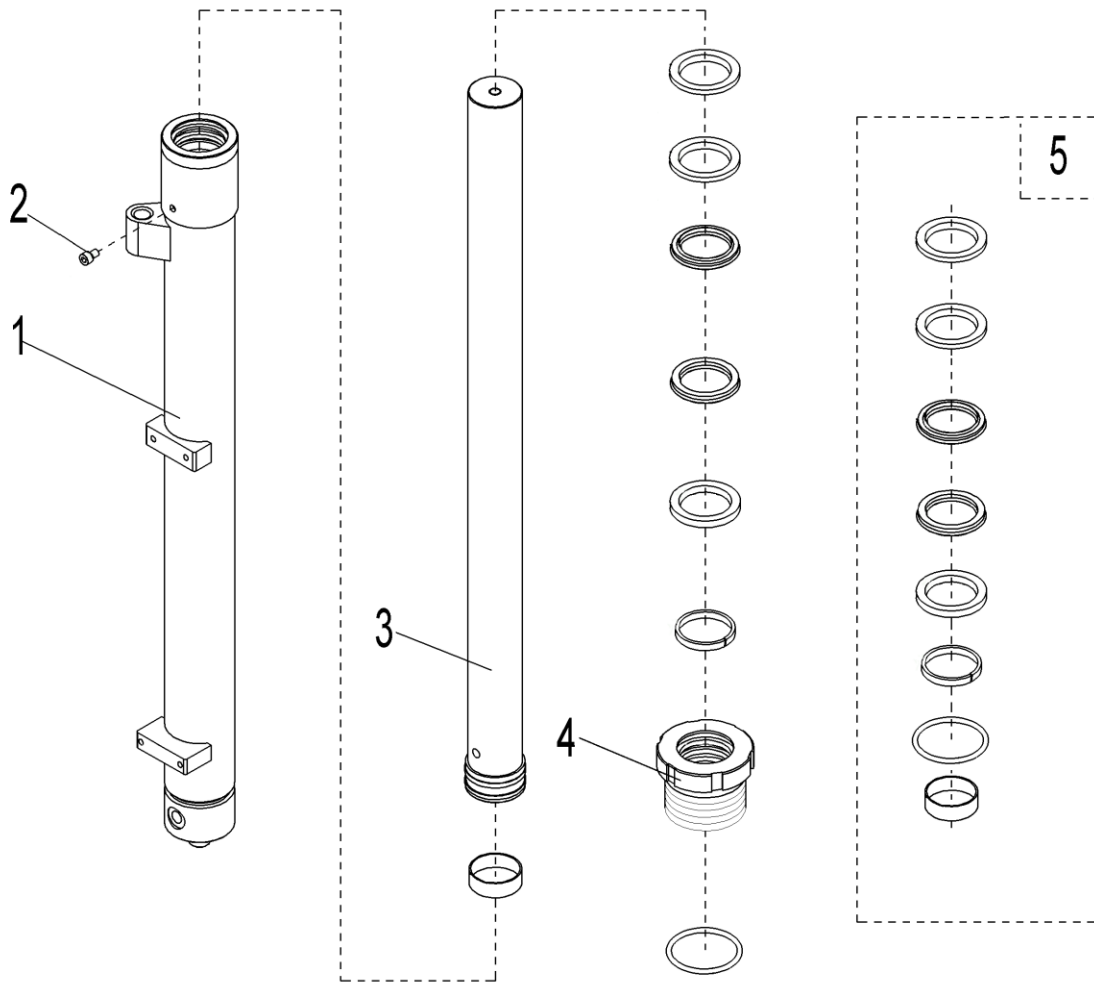

Fig.22 Middle cylinder (single mast)

No.	Art No.	Description	Qty.	Note
1	201098520043	Cylinder tube	1	1600
2	201098520032	Screw	1	M8x1
3	201098520048	Piston rod	1	1600
4	201098520053	End cap	1	
5	201098510006	Sealing components	1	

Fig.23 Driving system

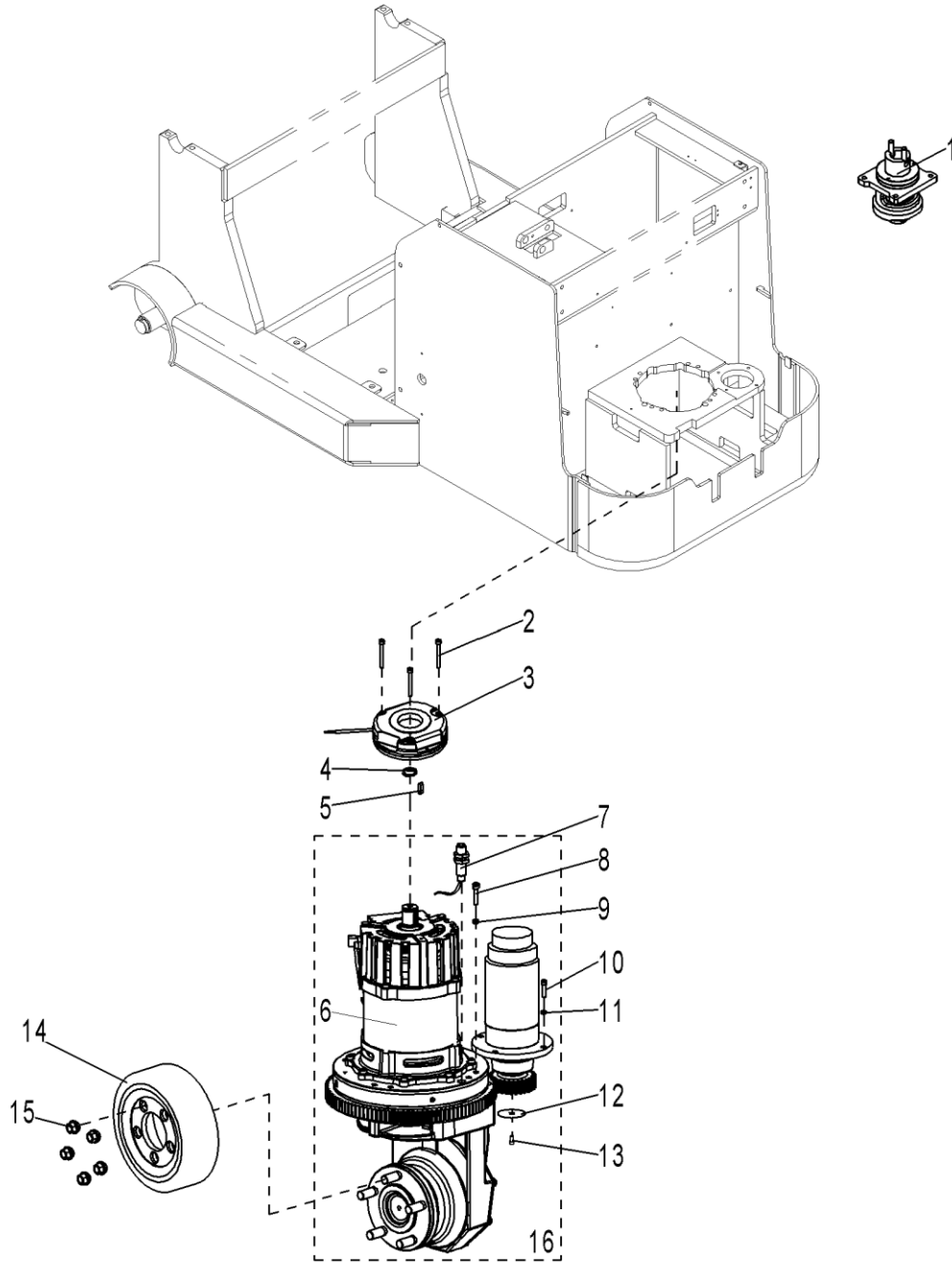

Fig.23 Driving system

No.	Art No.	Description	Qty.	Note
1	535931501001	EPS components	1	
2	910200200046	Screw	3	M6x60
3	940700100002	Brake	1	24v32N
4	910401300014	Retainer ring	1	25
5	910600800019	Flat key	1	8x20
6	940900600004	Drive unit	1	
7	920200400007	Proximity switch	1	Fi4-M12-ON6L-L70
8	910200200078	Screw	8	M10x35
9	910400500007	Spring washer	8	10
10	910200200059	Screw	4	M8x30
11	910400500006	Spring washer	4	8
12	506013520001	Baffle	1	
13	910200200057	Screw	1	M8x20
14	940300400002	Driving wheel	1	Φ250x82
15	275015520005	Nut	5	
16	506013501001	Driving assembly	1	

Fig.24 EPS components

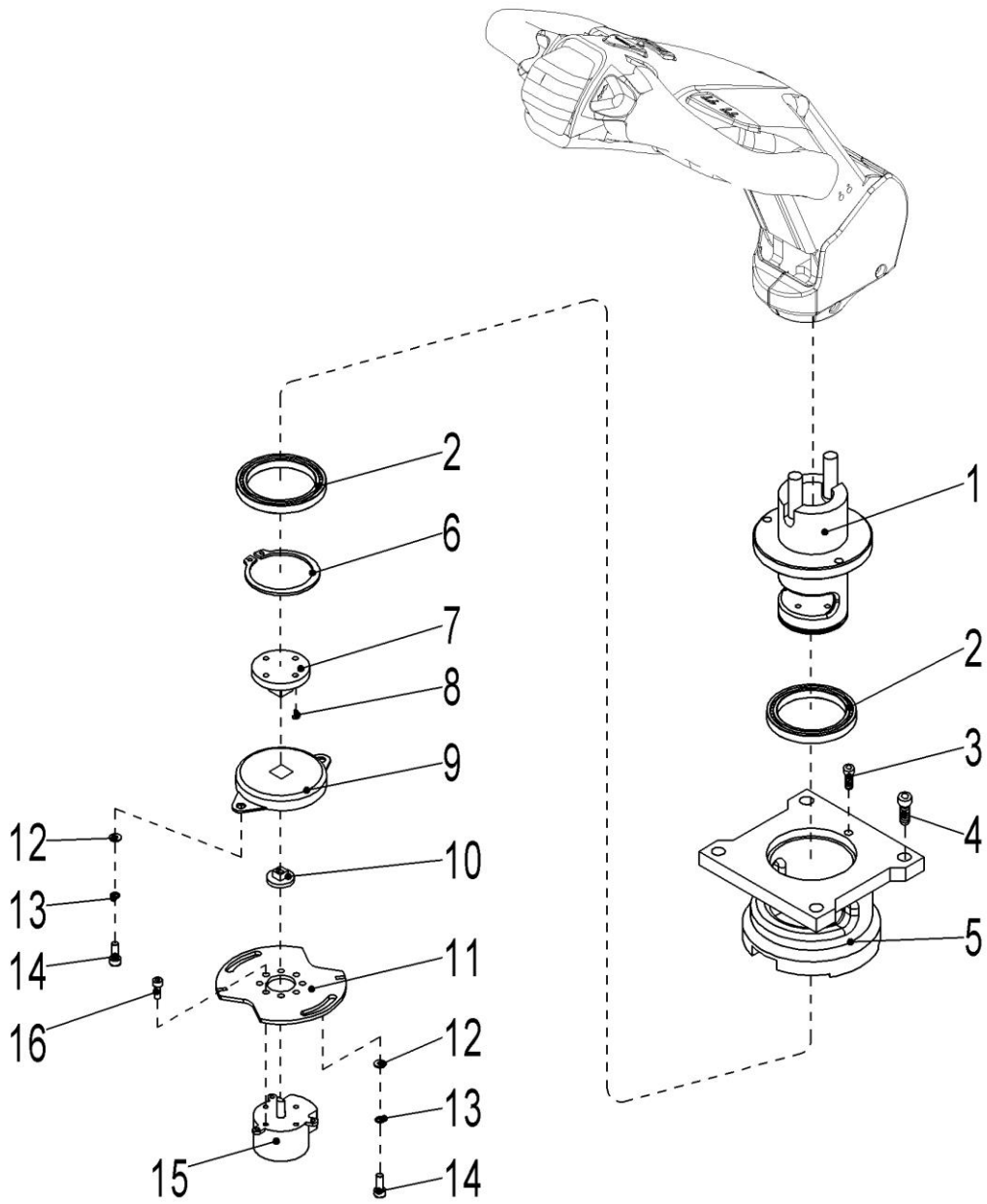

Fig.24 EPS components

No.	Art No.	Description	Qty.	Note
1	535931510001	Axle seat	1	
2	910700200041	Bearing	2	61810
3	910200200032	Screw	3	M6x10
4	910200200075	Screw	4	M10x20
5	505631520002	fixing seat	1	
6	910401300024	Retainer ring	1	50
7	505631520005	Adapting piece	1	
8	910200200013	Screw	1	M4x10
9	940801200001	damper	1	
10	505931520002	Adapting piece	1	
11	535931520002	Mounting plate	1	
12	910400100004	Flat washer	4	5
13	910400500004	Spring washer	4	5
14	910200200021	Screw	4	M5x10
15	921800200008	Potentiometer	1	
16	910200200014	Screw	4	M4x12

Fig.25 Driving assembly

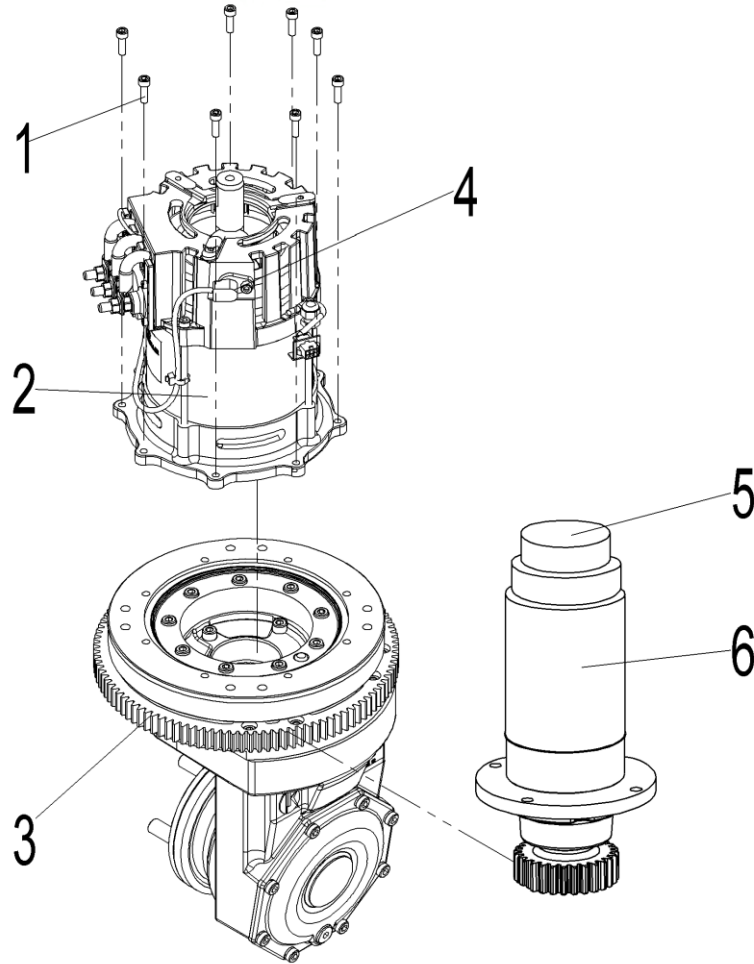

Fig.25 Driving assembly

No.	Art No.	Description	Qty.	Note
1	910200200036	Screw	8	M6x20
2	505998510010	Drive Motor	1	
3	505998510011	Gearbox	1	
4	505998510003	Sensor	1	
5	921800200016	Encoder	1	
6	920900100050	Steering Motor	1	

Fig.26 Hydraulic system

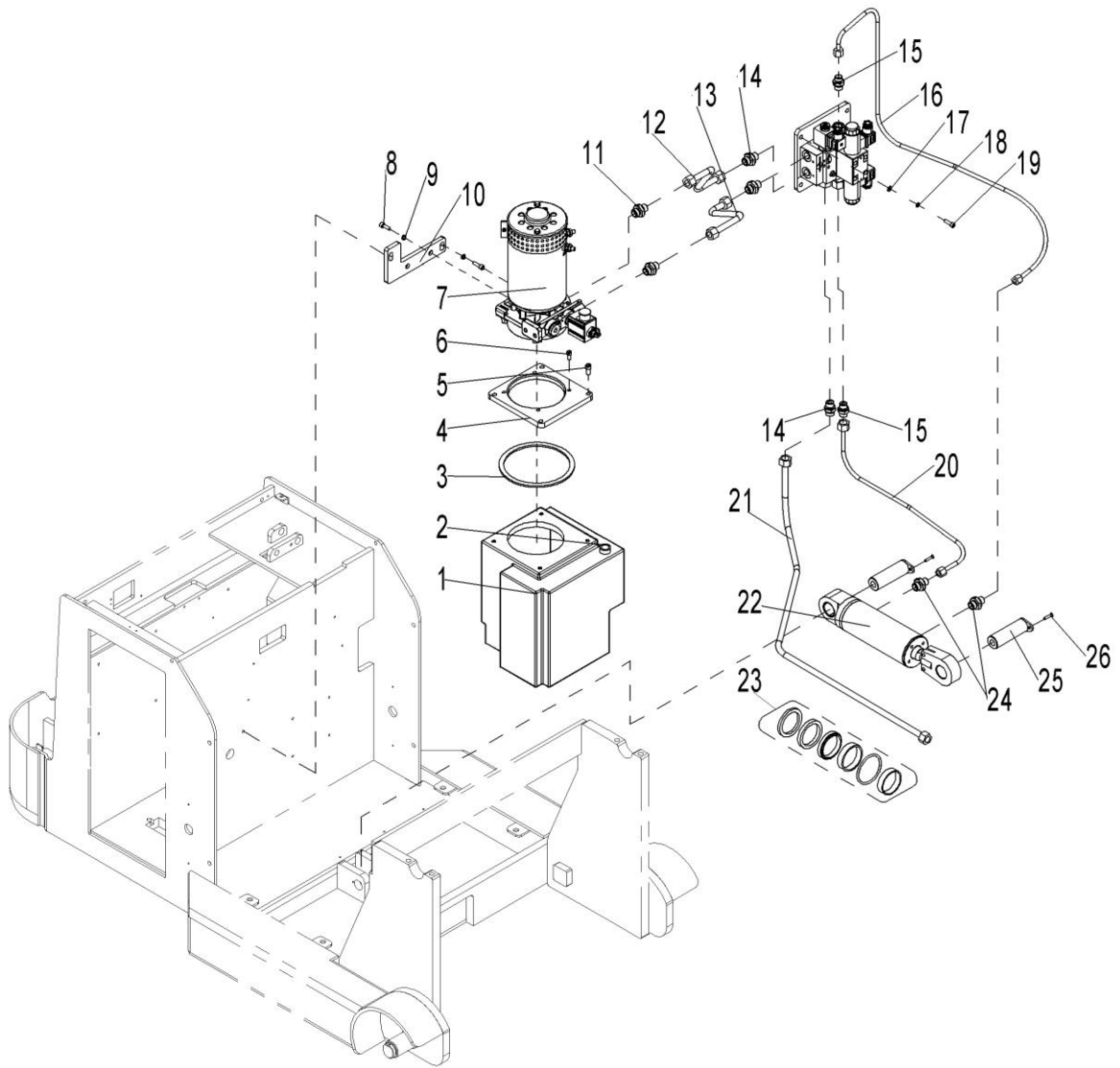

Fig.26 Hydraulic system

No.	Art No.	Description	Qty.	Note
1	535919020001	Oil tank	1	
2	951100200001	Vent plug	1	M18x1.5
3	535919020003	Rubber blanket	1	
4	535919020005	Mounting plate	1	
5	910200200057	Screw	4	M8x20

6	910200200034	Screw	4	M6x14
7	950900100015	Pump,24V3.2KW4.0cc	1	HPI
	950900100062	Pump,24V3.0KW3.3cc	1	VIBO
8	910200200074	Screw	4	M10x16
9	910400500007	Spring washer	4	10
10	535924020001	Mounting plate	1	
11	950400300008	Joint	2	
12	204424010003	Steel tube	1	HPI
	204424010011	Steel tube	1	VIBO
13	204424010002	Steel tube	1	HPI
	204424010012	Steel tube	1	VIBO
14	950400300009	Joint	3	
15	950400300004	Joint	2	
16	204424010013	Hydraulic hose	1	PSCB 12
	204424010007	Hydraulic hose	1	PSCB 16
	204424010009	Hydraulic hose	1	PSCB 18
17	910400100006	Flat washer	8	8
18	910400500006	Spring washer	8	8
19	910200200057	Screw	8	M8x20
20	204424010014	Hydraulic hose	1	PSCB 12
	204424010006	Hydraulic hose	1	PSCB 16
	204424010008	Hydraulic hose	1	PSCB 18
21	204424010015	Hydraulic hose	1	PSCB 12
	204424010004	Hydraulic hose	1	PSCB 16
	204424010010	Hydraulic hose	1	PSCB 18
22	204424010005	Cylinder(T)	1	Φ60xΦ32x65(2/4)
23	204498510000	Sealing components	1	
24	950400400001	Joint	2	
25	535045010008	Plate with shaft	2	
26	910200400016	Screw	2	M6x12

Fig.27 Pump,24V3.2KW4.0cc(HPI)

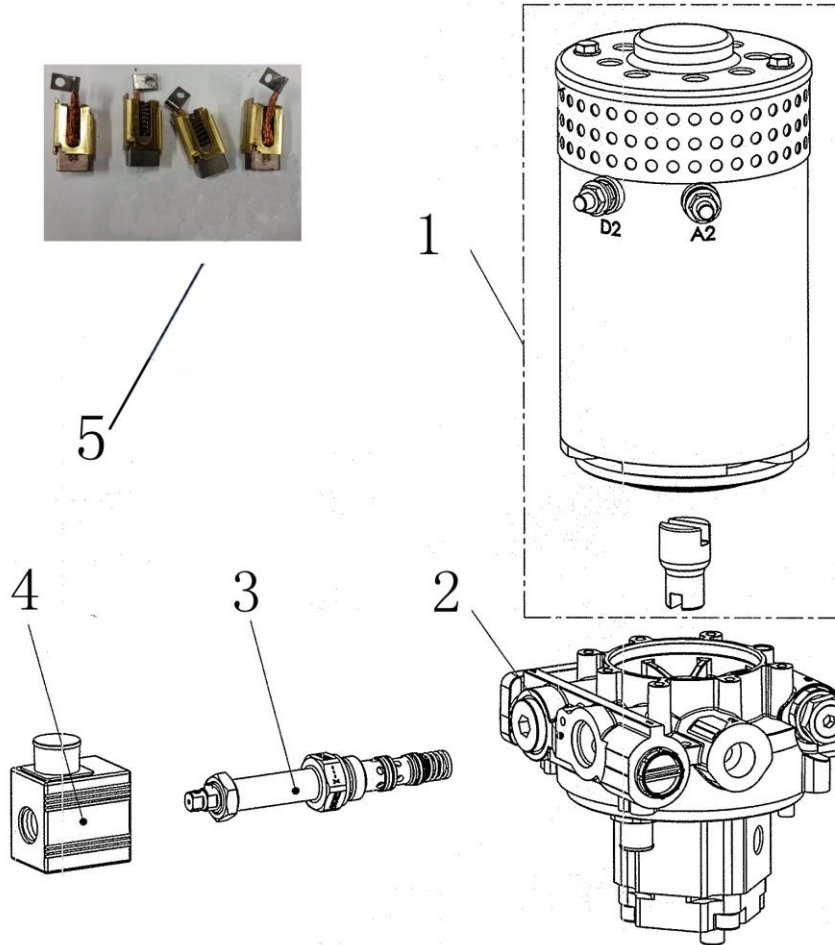

Fig.27 Pump,24V3.2KW4.0cc(HPI)

No.	Art No.	Description	Qty.	Note
1	534798510006	Motor	1	3.2KW
2	534798510007	Centre valve	1	
3	534798520024	Electromagnetic valve core	1	
4	534798520025	Coil	1	
5	534798520026	Carbon brush	1	

Fig.28 Pump,24V3.0KW3.3cc(VIBO)

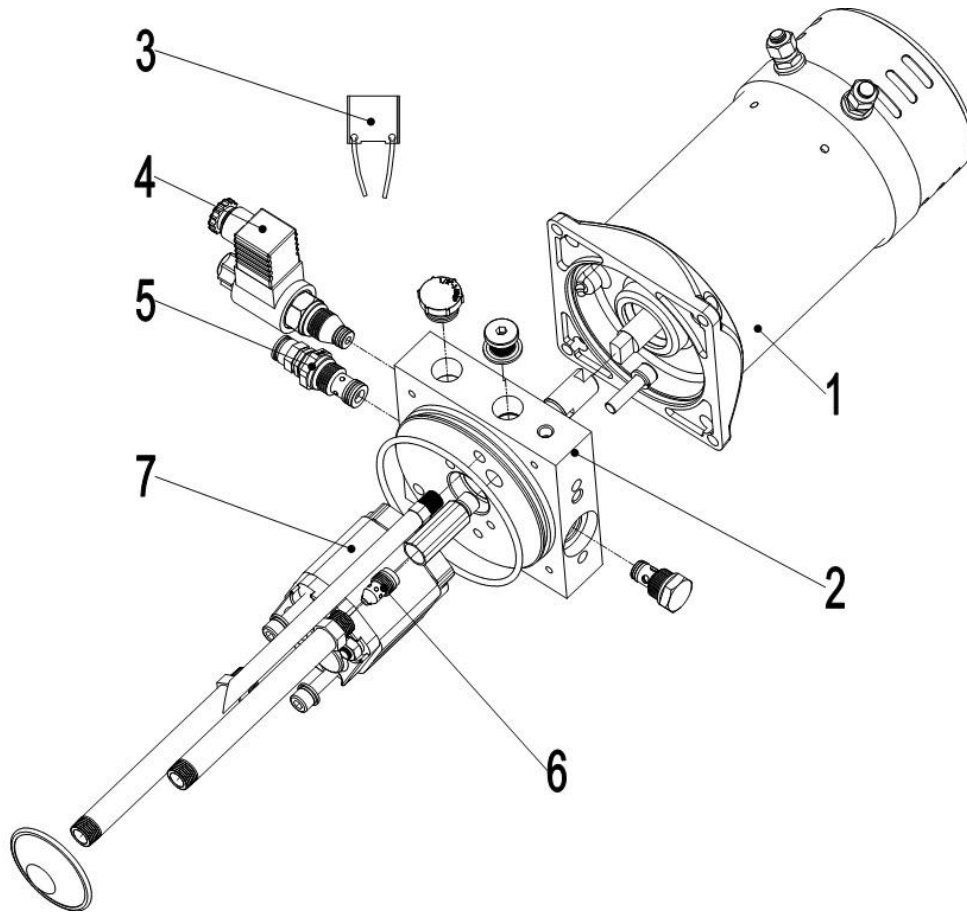

Fig.28 Pump,24V3.0KW3.3cc(VIBO)

No.	Art No.	Description	Qty.	Note
1	535998510008	Motor	1	
2	535998520018	Valve Block	1	
3	535998510013	Carbon Brush	1	
4	535998510009	Magnetic Valve	1	
5	535998510011	Overflow Valve	1	
6	535998510012	Valve	1	
7	505998510013	Gear Pump	1	

Fig.29 Work light

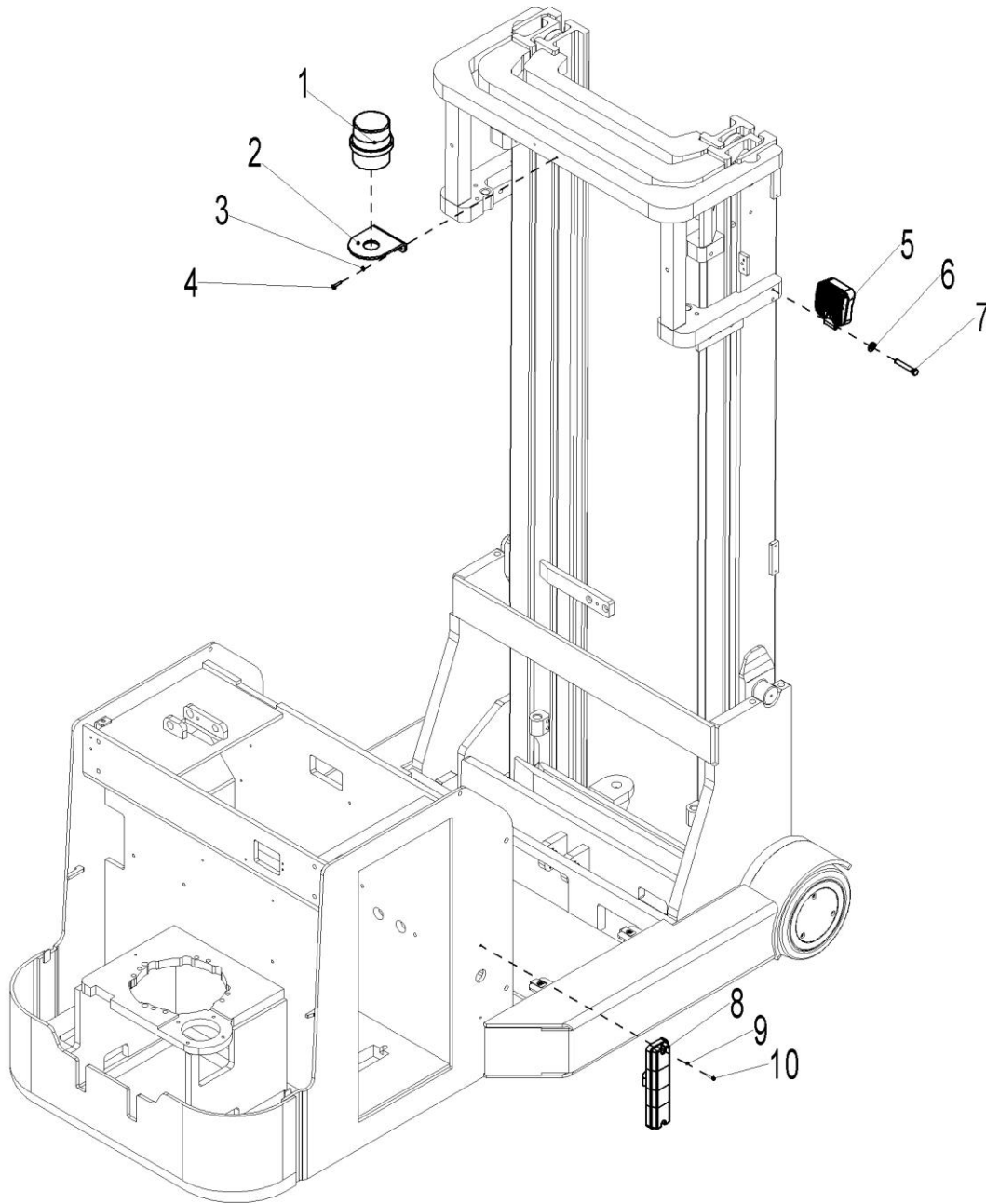

Fig.29 Work light

No.	Art No.	Description	Qty.	Note
1	213035501001	Caution light	1	
2	204444520005	Mounting plate	1	
3	910400100005	Flat washer	2	6
4	910200300016	Screw	2	M6x10
5	922000100001	Light	2	PDL-LXZM-1
6	910400100006	Flat washer	2	8
7	910100100023	Bolt	2	M8x45
8	922000100003	Light	2	PDL-LXHW-2
9	910400500004	Spring washer	4	5
10	910200500042	Screw	4	M5x25

Fig.30 Main circuit wiring harness

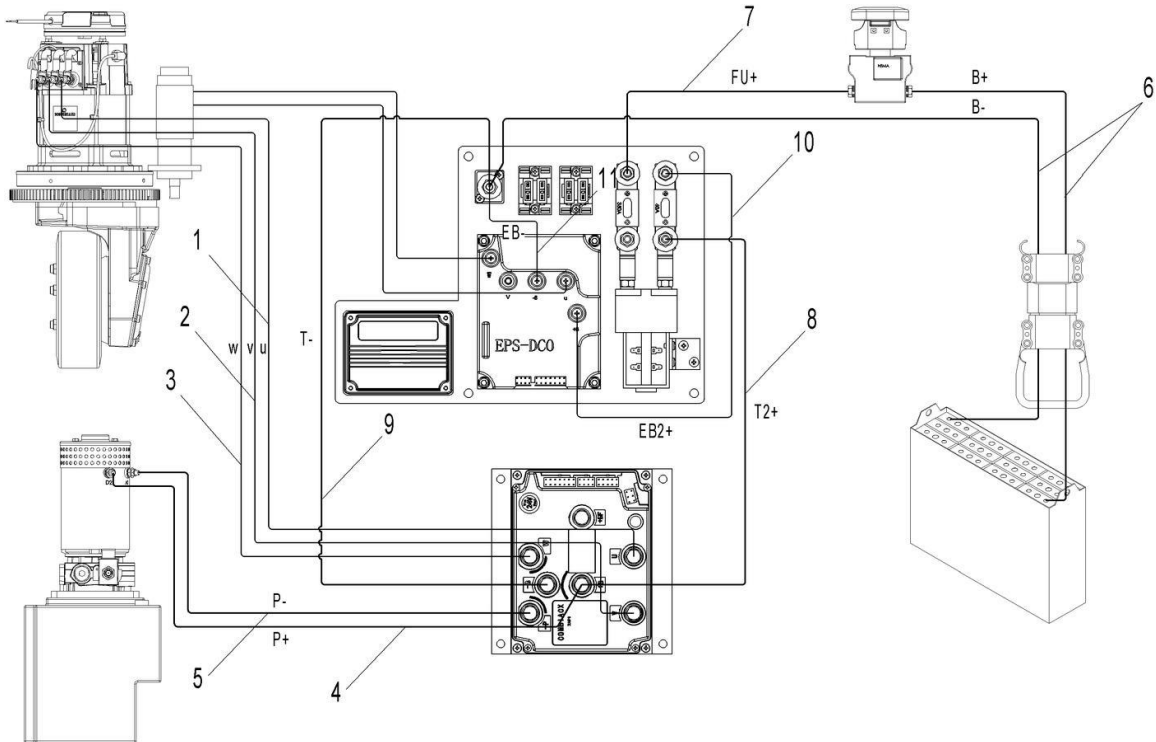

Fig.30 Main circuit wiring harness

No.	Art No.	Description	Qty.	Note
1	204433010004	Cable	1	U
2	204433010005	Cable	1	V
3	204433010006	Cable	1	W
4	204433010007	Cable	1	P+
5	204433010008	Cable	1	P-
6	204433010009	Main power supply wiring harness	1	
7	204433010010	Cable	1	FU+
8	204433010011	Cable	1	T2+
9	204433010012	Cable	1	T-
10	204433010013	Connecting cable	1	EB2+
11	204433010014	Connecting cable	1	EB-

Fig.31 Electrical control components

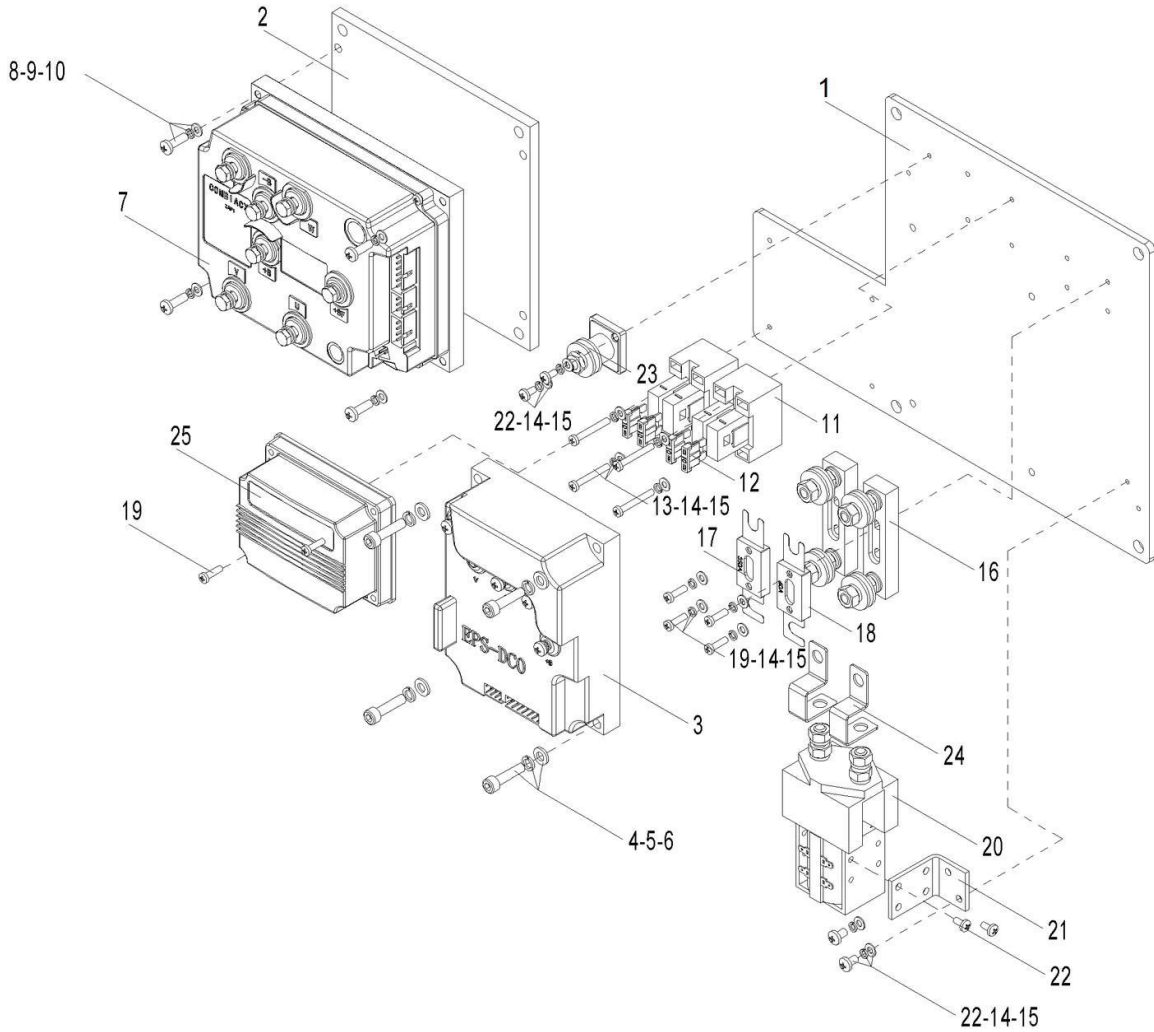

Fig.31 Electrical control components

No.	Art No.	Description	Qty.	Note
1	204433020000	Mounting plate	1	
2	534733020000	Aluminium	1	
3	921400100030	Controller	1	EPS-DC0-24V-50A
4	910400500005	Flat washer	4	6
5	910400500005	Spring washer	4	6

6	910200200036	Screw	4	M6x20
7	921400100048	Controller	1	COMBIACX24-240+ 270A
8	910400100004	Flat washer	4	5
9	910400500004	Spring washer	4	5
10	910200200023	Screw	4	M5x16
11	920100400005	Fuse base	2	BD-2x10A-1
12	920100200002	Fuse	4	10A
13	910400100003	Flat washer	12	4
14	910400500003	Spring washer	12	4
15	910400500003	Spring washer	4	4
16	920100400002	Fuse base	2	SY Y
17	920100100013	Fuse	1	350A
18	920100100003	Fuse	1	60A
19	910200500024	Screw	6	M4x16
20	920700100002	Contactor	1	DC24V-SW180B-4
21	921300400005	Main contactor fixing part	1	
22	910200500034	Screw	4	M4x8
23	920100400001	Fuse base	1	M8
24	565933020001	Copper bar	2	
25	921200100011	Module	1	FC2127-SCH.HVC

Easy worn parts list

No.	Art No.	Description	Qty.	Fig./Position	Note
1	940400100037	Air spring	2	Fig.4/2	Protective arm components
2	940500200003	Bushing	2	Fig.4/7	
3	505633510002	Proximity switch	1	Fig.4/16	
4	535933510000	Proximity switch	1	Fig.4/22	
5	535933510002	Proximity switch	1	Fig.10/15	Platform components
6	940500200008	Bushing	2	Fig.10/3	
7	940400100038	Air spring	1	Fig.10/12	
8	940300300025	Roller	1	Fig.11/1	Roller components
9	910700200025	Bearing	2	Fig.11/2	
10	202017001000	Roller assembly	1	Fig.11/7	
11	201098510005	Sealing components	1	Fig.19/12	Outer cylinder (full free lifting three-stage mast)
12	201098510006	Sealing components	1	Fig.20/12	Middle cylinder (full free lifting three-stage mast)
13	201098510005	Sealing components	1	Fig.21/12	Outer cylinder (standard lifting two-stage mast)
14	201098510006	Sealing components	1	Fig.22/12	Middle cylinder (single mast)
15	910700200041	Bearing	2	Fig.24/2	EPS components
16	505998510003	Sensor	1	Fig.25/4	Driving assembly
17	921800200016	Encoder	1	Fig.25/5	
18	204498510000	Seal assembly	1	Fig.26/23	Hydraulic system
19	534798520026	Carbon brush	1	Fig.27/5	Pump,24V3.2KW4.0cc(HPI)
20	535998510013	Carbon brush	1	Fig.28/3	Pump,24V3.0KW3.3cc(VIBO)
21	920100200002	Fuse	4	Fig.31/12	Electrical control components
22	920100100013	Fuse	1	Fig.31/17	
23	920100100003	Fuse	1	Fig.31/18	